

# RELAY IN TRANSLATION

Cay Dollerup

**Abstract:** This article focuses on the phenomenon of **relay** in translation. Relay is by nature difficult to discuss and therefore it is no surprise that even scholars who know of its existence usually do so only in passing. Scholars unaware of relay occasionally come across a relayed translation (namely a translation using a first translation from the language of the original as a relay). When they do so in comparative studies, they tend to consider the relayed rendition as either a poor or heavily manipulated translation. Historically, relay has been an important factor in translational activity. It is obscured by e.g. the **delay** in the spread of ‘international fame’ of prominent writers in the past as well as the fact that not all translators and publishers informed audiences that the translation they published was based on a translation from another language than that of the original text. The article attempts to differentiate ‘relayed translations’ from other types of non-direct translation. It discusses their occurrence in translation, interpreting, and subtitling, and ends with a few comments on how relay can(not) be tackled in practical translation work.

**Key words:** relay; indirect translation; retranslation; relayed translation; relay in interpreting

## 1. Introduction

Relay translation has not escaped the notice of all translation scholars but terminological ambiguities obscure its specific nature. And difficulties in obtaining all translational realisations needed for incisive discussions make exemplification difficult. In a review of a literary translator’s observations on ‘surprises’ in her own translation work, Gorlée (2007) briefly discusses relay in a passage that illustrates (a) problems of terms and definitions, (b) the disaffection among translators with the use of relay, (c) the difficulty of identifying it precisely, and (d) that it is mostly found in translation involving ‘small’ languages:

“Another example of surprising types of translations would be indirect translation [in the terminology in this article: **relay translation**], or translations two-layers-deep, as seen, for example, in the translations of Leo Tolstoy’s *War and Peace* (1862-1869) from, say, a German or French translation transplanted into a Dutch or Norwegian translation . . . . This somewhat surprising procedure tends to blur the unwanted details of the “original” source text and has been (and sometimes still is) common practice on the commercial market, particularly in the case of minority languages considered “exotic” target languages. The original text is so much modified through the historical, commercial, anthropological, political, ethical, and psychological differences presented in the secondary metatexts that its varieties make the argument of the original text disappear from sight” (Gorlée 2007: 346-347).

There are two obvious reasons why relay is often overlooked: Translation Studies focus on the source- and target texts and therefore intermediate text production is usually ignored; secondly, it is the source and target texts that are (out of necessity) central to teaching and training translation. My own attention was drawn to the effect the use of relay had on the audience, when, a couple of years after Danish had become one of the (then) six official languages at the precursor of today’s European Parliament, I came across a British journalist’s report from parliamentary proceedings: “It is interesting to see how jokes ripple through the audience: first the French and Belgians laugh, this is followed by British, Dutch and Italian

chuckles, and then finally, the Danes catch on and chortle” (quoted from memory from *Punch* c. 1975)

Having had a close look at the interpreting services of the European Commission, I recognised the mechanism behind this description. It is as follows: 1. A French-speaking delegate cracks a joke that is immediately understood by all French and Francophone Belgian delegates. 2. The joke is interpreted from French into (a) Dutch, (b) German, (c) Italian, and (e) English. 3. At the time, most Danish interpreters at the EU had no French, and accordingly they would use the English rendition as their source text. Since there is a time lag between the utterances in the source- and target languages, this explains the delayed Danish response.<sup>1</sup>

## 2. Definitions

To the best of my knowledge there are few studies and observations of relay. In this article, I shall refine the definitions and clarify points I have made in previous publications.<sup>2</sup>

Precise definitions are needed in order to have stringent discussions. Therefore I shall distinguish clearly between three types of translation in which we are dealing with two (or more) products of translation: retranslations; indirect translations; and ‘relayed’ translations. I shall also briefly consider ‘direct translation’ and, finally, look at ‘delay’ and ‘synchrony’.

There is agreement that a **direct translation** *involves two languages only*. Thus a translation from, say English into Romanian, is a ‘direct translation.’

Conversely, a **retranslation** is a new translation into the target language of an ‘original’ that has been translated before. A retranslation thus also *involves only two languages*. A retranslation can be prompted by a variety of reasons. In literature it is often ‘age’ or disaffection with existing translations that prompt retranslations (I once came across a Danish translation of A. A. Milne’s *Winnie the Pooh* in which the translator condemned the ‘errors’ of a previous translator). Language change, changes in ideology etc. may make previous translations outmoded or undesirable. And financial considerations (notably concerning copyright) may make a new publisher commission a new translation, etc.

Let me add that I do not consider translators’ revisions of their own produce retranslations. The main reason is that few translators will be fiercely critical of their own previous work and reject the first edition in its entirety.

An **indirect translation**, according to my definition, is a process that comprises an intermediate translation and therefore *involves three languages*. The intervening translation does not cater for a genuine audience and exists only in order to transfer a message from one language to another. This is a description of indirect translation used at a murder trial in Denmark:

The woman’s deposition reached the jury in circuitous ways, since it was first rendered from Thai into English by one interpreter and then into Danish by another interpreter.” (*Politiken* 12 September 1998, my translation)

The procedure was used because in a Danish court all legal proceedings must be in Danish: the witness’s account in Thai and the renditions into English carry no weight in themselves. The chain of translational communication is as follows.

<sup>1</sup> The time lag will differ according to the languages, the interpreters, the topic etc. Around 1975, professionals would say that it was about five seconds between the six languages (all Indo-European) then used at the EU.

<sup>2</sup> These previous publications are accessible at [www.cay-dollerup.dk/publications](http://www.cay-dollerup.dk/publications).

The sender makes her statement in L<sub>1</sub> (Thai)

Interpreter A renders this into L<sub>2</sub> (English)

Interpreter B renders this into L<sub>3</sub> (Danish) to the addressees.

This, of course, leads to questions by the judge or by the councils for the defence and for the prosecution in L<sub>3</sub> (Danish).

Interpreter B renders this into L<sub>2</sub> (English), and

Interpreter A renders this into L<sub>1</sub> (Thai).

The witness answers in Thai which is rendered into English by interpreter A, etc.

The characteristics of an indirect translation are that:

- all senders, mediators and recipients know that the intermediate translation is merely a stage in the communication between the parties directly interested: the senders and the recipients;
- therefore the intermediate translation is not directed towards an 'authentic audience'.

Since the mediator is not swayed by considerations for any audience in indirect translation, there are no obvious situational factors that affect the intermediate translation into L<sub>2</sub>. I suggest that in real life, indirect translation by this stringent definition is relatively rare but not unheard of in multilingual settings.

By contrast a **relayed translation** is based on a translation that has a genuine audience in the first target language. Like indirect translation, it spans realisations *in three languages* (viz. the source text, the first translation and the relayed translation). When the first translation is chosen for the source text for the 'next' translation, the first translation becomes a **relay**. We may consider the example of a Romanian book that is translated into French and subsequently from French into Swedish:

The French translator rendered the Romanian source text (L<sub>1</sub>) for a French audience (L<sub>2</sub>) and had no inkling that later on the translation would come to serve as a source text for a Swedish translation. Since the book was destined for French readers, the translator oriented the text towards Frenchmen, e.g. by paying attention to 'style' (however we define it), by explaining special Romanian features and so on. In previous epochs publishers and translators often 'took liberties' with translations. And today most publishing houses edit all books they publish in order not to jar reader sensibilities and make for better sales. They usually do so without consulting authors and translators. In sum: in some measure or other the target text is oriented towards (or adapted to) a French audience.

Years later, the French translation (L<sub>2</sub>) is chosen as the source text for a Swedish translator who, in the process of translation, makes sure the book will meet the expectations of a Swedish audience (L<sub>3</sub>). It goes without saying that the translator does not know what adaptations were made in the French version.

The characteristics of a relayed translation (L<sub>3</sub>) are that

- the 'original' source text has an audience in the source-language and its culture<sub>1</sub>;
- the translation into L<sub>2</sub> was made by a translator who knew that it was made for an audience in the target language and culture (L and C<sub>2</sub>).
- when this translation (L<sub>2</sub>) serves as a source text for a subsequent translation into L<sub>3</sub>, the translation in L<sub>2</sub> **becomes a relay** for the **relayed** translation that has an audience in the third culture (L<sub>3</sub>).

In principle, the translational chains of communication involving relay and relayed translations can be continued for ever as follows:

- 1. Source text -> audience 1 + translator
- 2. Translation 1 -> audience 2 + translator
- 3. Translation 2 -> audience 3 + translator
- 4. Translation 3 -> audience 4 + translator, etc.

Some of the most popular works in world literature such as the fairytales of the brothers Grimm and Hans Christian Andersen as well as the dramas of William Shakespeare have been through this process. In Andersen's case the chain went:

Danish > German > Romanian

Danish > German > English > Japanese > Chinese.

Popular books will soon have more adequate translations replace previous ones with obvious errors (one early German translation of Andersen thus had the princess in *The Princess and the Pea* sleep on two peas rather than only one.) Yet scholars may find traces in the relayed translation of audience-adaptation in the intermediate source-texts. In a study of Romanian translations of the English writer Daniel Defoe's *Robinson Crusoe*, Dimitriu (2006) has thus found that the Romanian translation relayed via French reflected French manners and that Robinson's parrot had a French name (Jacquot).

When translations have been through numerous relays, it may be very hard to recognise that the 'original' was the same: witness the following translations of the opening of the brother Grimm's *Snow White and Rose Red*

- into Danish (from Italian 1973): "There was once a poor widow who lived in a cottage in the wood with her daughter. One was called Snow White and the other Rose Red, and they were both diligent and nice girls." (My translation)
- into Danish (from Dutch 1975): "There was once a poor widow who lived in a cottage in the wood with her daughters. In her garden grew two exceedingly beautiful rose bushes, and every year one of them flourished with snow white blooms and the other one with blood red ones – and the woman named her daughters after them." (My translation)

It goes without saying that in epochs when national taste was imposed on translations as a matter of course, renditions were not at all 'faithful' to the contents, neither in the first translation, the relay, nor in subsequent relayed translations. This is exemplified in *Arabian Nights*.

*Arabian Nights* (Indian, Persian etc.) was first translated into French from Arabic by J. A. Galland (1704-1717). Only 25% of the stories in the Arabic version were rendered in the French translation and many crude passages were not translated. Nevertheless, it served as a source text for numerous relayed translations in other European languages such as English (The "Grub Street version" 1705) and Danish (1757-1758).

In modern literary translation most transfers are probably direct. Yet, as mentioned by Dinda Gorlée (above), relayed translations will be published with 'exotic language combinations' when no translator can undertake a direct translation.

Relay in translation work is not confined to literary translation.

Relay was used in consecutive interpreting when several languages were in play, but being time consuming, it has, nowadays been replaced by simultaneous and it is rarely found in developed countries today. Relay is used in simultaneous conference interpreting at EU institutions, especially in the Parliament where all MEPs (tend to) speak their national language. Previously some users and many outside observers believed that the use of relay in simultaneous interpreting led to numerous errors. Having listened fairly systematically to interpreting, my assessment (in the 1970s) was that the actual number of errors must be very low. I never found indisputable errors due to relay. The ones I pinned down were caused by the original senders (and would then lead to errors in the first rendition): delegates mumbled, they turned their faces, they spoke dialect, they quoted figures in incomprehensible ways, etc. (for a practicing interpreter's views on this, see Pearl 1995).

In professional, high-level conference interpreting, relay does not lead to many misunderstandings. This is not surprising since professional interpreters are trained in delivering extremely well-phrased and easily understood produce.

Relay is also found in some subtitling when the original language is found on the soundtrack and this is subtitled into the ‘original language of the film’ as we see it in the below illustration of an English film that unexpectedly introduces Italian speech which is then translated into English for English audiences and relayed from English in Danish subtitles for the Danish audience.

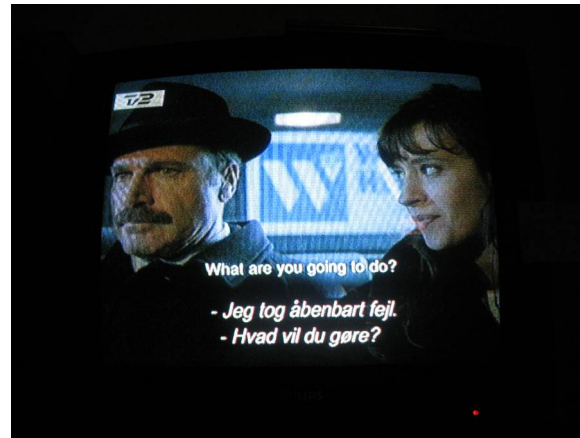

The use of relay affects relayed subtitling much more in ‘cueing’, a technical procedure known only to subtitlers and consequently not detected by audiences. Cueing is used to save money by large subtitling firms that cover several languages (A, B, C, D ...). The first subtitler makes his or her subtitles (into A) and then enters ‘cues’ (‘marks’) for the beginning point of these subtitles on diskette or in programme. Subsequent subtitlers that work into B, C and D ... must use the first subtitles as their source texts (relays), and also have to insert their renditions at the cues and confine their subtitles to the length allowed by the first subtitle.

### 3. The time dimension: relays and delays

In the literary examples discussed above there was a pronounced delay between the appearance of the original, the first translations and subsequent relayed translations. It took de-cennia or centuries for Shakespeare, Defoe, the brothers Grimm and Hans Christian Andersen to become ‘world famous.’

Today all modes of translation are under constant change: they are transformed by e.g. language change, technological advances (microphones, computers, etc.). And new professions are emerging on the language scene (e.g. subtitling and simultaneous conference interpreting).

Therefore it is not surprising that ‘relayed translation’, slippery as it is, moves in and out of the modes and changes its form from one situational context to another.

### 4. Factors in relay

It is useful to have a look at the factors that affect relay.

There is no fundamental difference between a direct translation and the first translation that serves as the relay for subsequent relayed translations. This follows from the fact that the

first translation in a relay chain is made with only the first-language audience in mind. The inevitable asymmetry in terms of vocabulary, syntax, etc. between the source and target language are the same. And since translators of both types work for well-defined audience and/or clients, there is some audience-orientation in the translation process. This target orientation may involve any strategy spanning from the most literal rendition (e.g. with legal and religious texts) to free renditions (e.g. of children's literature or popular music) and from insertion of notes to rephrasing.

In real life, the second translator will know that the source text is not the 'original' since there is ample confirmation in, e.g. the contents, the identity of the sender (author) or the title, and in subtitling (DVDs, films and television) from the cast, the sound track etc. It is rare for translations that serve as relays to be discussed since they are hard to identify, let alone to get hold of.<sup>3</sup> It follows from the nature of relay that the translator involved does not command the 'original' source language.

Nevertheless, there is one notable exception in which those who render relayed translations can make a choice between different source-texts or relays.

This happens in simultaneous conference interpreting at some of international organisations such as the EU and the United Nations when the original source message is rendered into two and more languages by the first 'wave' of interpreters who may potentially serve as relay for the interpreters who do not understand the 'original language':

### 'Control' mechanism (simultaneous)

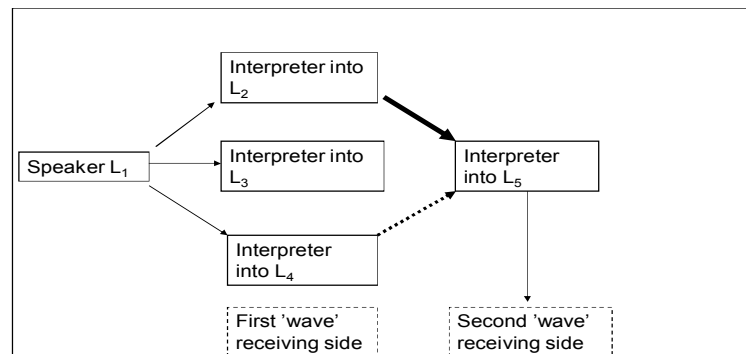

27

Interpreters doing relayed interpreting can choose between renditions they understand in the first relay. There is no doubt that the most important parameter determining their choice will be the assessment of superior quality. But even here, we are discussing only the first translation.

As far as relayed translation (the secondary translation) is concerned, the sobering reality is that the recipients are helpless even when they feel it may deviate from the original. Their chances of identifying mistakes are just as slim as those of professional translators who suspect that there may be an error in a relay translation. The possibilities of checking and correcting are small. The end users face only the relayed translations. It is difficult to track down a source of error back in time and it would also require a command of languages that few users

<sup>3</sup> Zilberdik's article is unusual in that she identified and compared (1) the Danish source text, (2) the English text used for the relay, and (3) the Israeli subtitles relayed from English.

of relayed translations have. One can usually not move beyond a vague suspicion that there may be an error somewhere in the translational chain.

#### 4. Three cases involving relay

A few examples will serve to illustrate how tricky relay is and some ways it is received, tackled and traced. Let me stress that this merely shows how difficult it is to discuss relay.

The first one is from a review in a Danish national newspaper of a novel *The trapeze of memories* (*Politiken* 14 February 2008). The book was written in Arabic by the Iraqi-born Muniam Alfaker.

The novel was translated into French by Touria Ikbal. Subsequently, it was translated into Danish by Sejer Andersen (2007). The reviewer was enthusiastic: “In its specific, mitigating way the humour typical of the novel appears time and again: ”I’m scared of two things, my wife and the government,” says one man to another in one passage. One does not know whether to laugh or cry.” Here, then, the chain of translational communication functions well in the eyes of the reviewer.

The second example derives from an experienced Danish translator of children’s stories (Mette Jørgensen, p.c.). She was asked to do a translation of a Dutch children’s book and received an English text from the publisher. She found this translation too tame for the illustrations and concluded that the English text had been made only in order to promote sales of the book with publishers (the book was a co-print i.e. an international book destined for many different markets with the same illustrations and with ‘localised’, national texts).<sup>4</sup> Knowing some Dutch, she procured the Dutch original and consequently did an adequate translation. In this case, the first translation to be used in the chain of relay was bypassed and ignored because of its inferior quality.

The third case concerns the instructions on an inflatable mattress that mystified me at first sight. The mattress was produced in China and the warning ran as follows:

注意：仅在适当监护下使用。

The English translation was “Use only under competent supervision”. The German translation ran *Nur unter Aufsicht von Erwachsenen zu benutzen* ‘To be used only in the presence of/under the supervision of adults’.

I suggest that the Chinese text covers both the concepts of adult and competent (perhaps in one comprehensive term). The translator doing the translation into English focussed on ‘competence’. The English translation served as the source text for Italian, Danish and some other languages.

The translator who did the German translation realised the Chinese concept linguistically as ‘adult’. This German translation then served as the source text for Dutch, Spanish, Portuguese, Norwegian and Swedish.

Provided my hypothesis is correct, this is an example of how the choices made by the first translators for their target texts may have repercussions in relayed translations.<sup>5</sup>

<sup>4</sup> Nowadays most international sales work in the publishing world takes place at international book fairs, notably the annual ones in Frankfurt (Germany) and Bologna (Italy).

<sup>5</sup> Many Chinese translations are done by Chinese teams of translators. They often rely heavily on dictionaries so the different translations might be due to different interpretations of dictionary entries.

### 5. Relay in the future

There is no doubt that when there are no linguistic middlemen for rendering a direct translation, relay will continue to exist. However, in the future globalised world, the use of relay will decrease in international cooperation. There is little doubt that English will become the dominant language of international communication and consequently a command of English will be a must for everybody who wants to play a role on tomorrow's stage.

At the EU, it is a matter of principle that all translators should only work into their mother tongue. Nonetheless I believe that with the future expansions of the EU it is only a question of time before we shall see a system like the following one in operation, at least with minor languages:

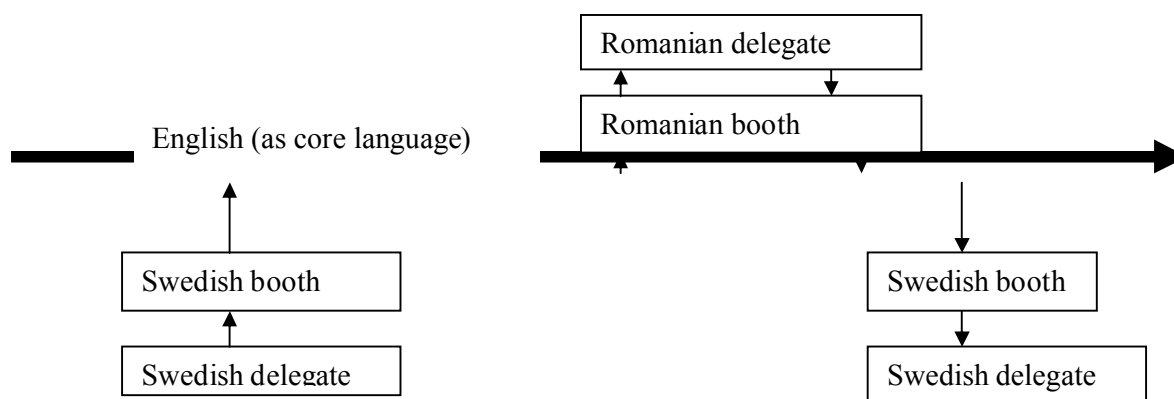

This is then, a hypothetical sketch of the future: a Swedish delegate speaks Swedish. This is interpreted into English which then functions as a relay for the relayed rendition into Romanian. The Romanian delegate answers and, via English, there is a relayed rendition of the response in Swedish. It is thus my prediction that in the long run, interpreters of 'minor' languages will have to interpret both ways that is both into and out of their native language. This is a controversial view but such procedures were used in an embryonic form with the many nations participating in the Congress of Vienna (1814-1815) after the Napoleonic Wars as well as in such organisations as the COMECON in the Soviet era.<sup>6</sup>

No matter whether this comes true at the EU or not, my illustration also implies that English is becoming central to international communication. It is a process that we are observing and which is therefore affecting not only language workers but also politicians, future language workers and university programmes.

Even when there are language professionals who are hired for assistance, many people at multilingual meetings will (try to) use one and the same language for communication. This **contact language** is normally English. A contact language is by nature quite distinct from 'relay' because it involves only *one language* (in many versions). In this context, the concept of contact languages heightens our awareness of the increasing complexity of human communication. This complexity is one of the factors that make it difficult to uphold strict definitions in the field of translation.

<sup>6</sup> At the 'Congress of Vienna' the core language was French and at the COMECON it was Russian. Interpreters must have had to work 'both ways'.

## 6. Delay vs. synchrony

Above, it was pointed out that ‘delay’ was formerly prominent – indeed present - in all translation work (with the exception of whispered (simultaneous) interpreting). However, today there is a high degree of **near-instanteniety and near-synchrony** between the production of the source and target texts (e.g. in simultaneous interpreting, technical manuals, instructions, films, etc. including books!). This will automatically make for easier (but not necessarily always systematic) ‘control’: Control will vary from relatively much at the EU and UN to haphazard when language-savvy consumers come across tourist brochures or manuals in which they suspect translation errors.

The fuzzy line between ‘indirect translation’ as I defined it and relay is disappearing (once again: not systematically). They are fusing. In addition, many of the distinctions formerly made between translation and other modes of international communication are dissolving.

## 7. What can translators do?

We must pose one final question, namely “what can translators and scholars do?” (two different groups in this context) – and remember that much relayed translation cannot be identified for what it is.

Translators may become suspicious when there is ambiguity, strange phrasing, inconsistency, and lack of coherence in the first translation. Unless they can consult somebody who commands the original source language (and thus circumvent the relay), there is precious little they can do, except for taking recourse to the following inadequate measures – provided they have access to the L<sub>1</sub> source text:

- check the punctuation which is usually calqued in translation.
- use translations into languages they command in order to see on how the source text is rendered in these languages. And
- check the L<sub>1</sub> version typographically with the length of the L<sub>2</sub> version (which must, however, allow for the fact that some languages are ‘wordier’ than others: Russian target texts are c. 25% longer than source text, whereas Chinese target texts are much shorter than most other language texts).

Whatever measures are taken, it is impossible to avoid content deviations (and stylistic infelicities) that have been introduced in the first translation in practical relay translation work – even for the most conscientious translator.

## 8. Conclusion

In all likelihood, ‘relay’ will not disappear from translational contexts. It will, I believe, come into existence on an unpredictable ‘ad hoc’ basis in the same fashion that it has, so far, usually been the outcome of coincidence and circumstances rather than planned thinking on the part of the ‘sending side.’

It is not stable: it differs between language combinations, text types, periods, etc. Its existence is another parameter in addition to those we already know in translation criticism. Some people believe it introduces numerous errors but this is not necessarily the case.

It is not worthwhile making relay the object of major scholarly studies. At best such critical studies can argue that special types of error that turn up frequently in specific language combinations in ‘relay’ chains are typical of these chains. But it is unlikely that studies of ‘relay’ are relevant except on the broadest terms (like this article) to Translation Studies in general.

On the other hand, it is important that scholars are always aware of the possibility that a translation is relayed. It is unwise to ignore it completely, especially in translation criticism.

Cay Dollerup  
Copenhagen, Denmark  
www.cay-dollerup.dk

### References

- Dimitriu, R. 2006. From Robinson Crusoe to Robinson in Wallachia. The intricacies of the reception process. In M. Shlesinger, Z. Jettmarová, A. Pym (eds.), *Sociocultural Aspects of Translation and Interpreting*, 73-82. Amsterdam/Philadelphia: John Benjamins.
- Gorlée, D. 2007. Bending back and breaking [a review of Mary Ann Caws *Surprised in Translation*]. *Symplokē* 15: 341-352.
- Pearl, S. 1995. Lacuna, myth and shibboleth in the teaching of simultaneous interpreting. *Perspectives: Studies in Translatology* 3: 161-190.
- Zilberdik, N. J. 2004. Relay translation in subtitling. *Perspectives: Studies in Translatology* 12: 31-55.