

## ***THE STRUCTURE OF THE IMPLICIT IMAGINARY IN THE FIRST-PERSON EMBEDDED NARRATIVE***

**Carmen DOMINTE\***

**Abstract:** *Defined by Iser as a part of the series real-fictive-imaginary and considered an inactive potential with no intentionality of its own, imaginary needs a medium for its manifestation, created by the fictive and, for being activated, an external intervention provided by the social and historical conditions (Castoriadis), by the subject (Coleridge) or by the consciousness (Sartre). Placed in a narrative text, imaginary depends on the positions and perspectives of the narrator(s), of the character(s) and of other entities belonging to the same fictional world. In a first-embedded narrative, the narrator's and protagonist's imaginary are implicit, featuring each other and functioning as a core element for both the frame story and the inside story. The study intends to develop the basic structure of implicit imaginary for framed narratives which include more than one fictional world generating the reversed implicit imaginary, the related implicit imaginary and the multiple implicit imaginary.*

**Keywords:** *imaginary, embedded narrative, first-person narrator, fictional world.*

### **The First-Person Embedded Narrative**

Generally speaking, an embedded or framed narrative represents a text placed within another text; but embedding is not a mere positioning, it also involves a lot of narrative relationships established among the narrative instances that are to be identified within a fictional world. The most important one is the narrator, the instance that assumes the act of narrating the story. At the same time, the character represents another narrative instance involved in the act of telling the story but developing other narrative functions. Being characterized by Roland Barthes as instances of paper, the narrator and the character share the same fictional world. (Barthes, 1966: 19)

A well-defined model of narrative functions that are to be used by the narrator as well as the character was set by Lubomir Doležel. The theoretician distinguished between the primary or mandatory and secondary or optional functions. Assuming the narrative act, the narrator carries out the primary function of narrative representation while the essential aim of the character is to take part in the fictional act as *dramatis persona*, developing an acting function. Another primary function is the function of narrative control. In this case, the narrator is allowed to insert the character's discourse into his/her own discourse but the opposite is impossible. The character is always able to express his/her subjective attitude fulfilling the performing function. These two mandatory functions could change places so that the narrator's primary functions may become the character's secondary functions and

---

\* National University of Music, Bucharest, [carmendominte2@gmail.com](mailto:carmendominte2@gmail.com)

the character's primary functions can be used as the narrator's secondary functions<sup>1</sup>. Thus, the narrator may state his/her ideological position by developing the performing function. Furthermore, the acting function could be used by the narrator in the case he/she identifies himself/herself with a character that, from now on, would assume the narrative function of representation and control neutralizing the functional opposition between the narrator and the character. (Doležel, 1973: 6-7) But this opposition may not be completely abandoned since there are narrative situations when the character like Scheherazade develops both the acting function as character-actor (object of the narrative act or narrated character) and the function of representation as character-narrator (subject of the narrating act or narrating character) and not only the acting function as Père Goriot. For this reason and also for avoiding any ambiguity, the notion of character becomes inappropriate for a model of narrative functions and it may be replaced by the notion of *hero*, using Rousset's terminology. (Rousset, 1973: 17) At the same time, the term *actor* from Greimas' theory proves to be very useful for this task. (Greimas, 1973: 161-162)

Although Doležel considered that in the first-person narrative there could be a functional assimilation concerning the narrator and character mainly because the character is fulfilling the function of representation as well as the acting function, there still be maintained the dichotomy<sup>2</sup> between the character-narrator that assumes the narrative function and the character-actor developing the acting function. More than that, inside the *narrated world* generated by the narrator, there could be inserted the *quoted world* made of the actors' discourses. Each actor reveals his/her ideological position being able to confirm, contest or fill in the other ideological positions belonging to the fictional world. The assimilation between the narrator and the character was contested by Gérard Genette who set the difference between the character's point of view which generates the narrative perspective and the narrator. (Genette, 1972: 203) These two narrative perspectives should not be confused either it is a first-person or third-person narrative in which case a character like Emma Bovary is developing the acting function while the narrator is assuming not only the function of representation presenting everything that is perceived by Madame Bovary, but also the function of control as he is the one that may refer to Emma's discourse through *verba dicendi* and *sentiendi* or other types of setting indicators while for Emma would be completely impossible to make any reference to the narrator's discourse.

The act of narrating is meant to produce narrative texts containing the narrator's discourse and the actors' discourses quoted by the narrator and this alternative combination of discourses gives *le discours* in Tzvetlan Todorov's terms. At the same time and using the same terminology, *le histoire* or *diegesis* is formed by the narrated world based on the

---

<sup>1</sup> Wayne Booth and Lubomir Doležel believed in the possibility of transferring any character into a narrator but Gérard Genette and Jaap Lintvelt made a firm dissociation between the two narrative instances.

<sup>2</sup> According to Doležel studies, the opposition between the narrator and the character may be also neutralized in the third-person narrative when the narrator identifies himself/herself with one of the characters. (Doležel, 1973: 8) Giving as an example the case of Emma Bovary who assumes the function of representation as well as the acting function, Doležel shares the same opinion as Wayne Booth, according to whom any narrative perspective based on a character's consciousness turns this character into a narrator. (Booth, 1961: 164)

characters' actions which become the object of the narrator's discourse and by the quoted world which reveals the narrative events as presented by the characters. (Todorov, 1966: 126-127) The aforementioned narrative instances of narrator and actor are generating a narrative system which, from the semiotic point of view, may be regarded as a hierarchy consisting of several narrative levels. Each narrative level<sup>1</sup> is meant to describe the relationship among the narrative instances and also serves to indicate the spatiotemporal relationships between the various narrating acts belonging to a narrative. The functional opposition between the narrator and the character leads to the dichotomy between the *heterodiegetic* narrative and *homodiegetic* narrative. (Genette, 1972: 252) A narrative may be considered *heterodiegetic* in the situation the narrator is absent from the narrated world and *homodiegetic* when the narrator is present in the narrated world. Both types of narratives could be identified in a framed story since there are more than one narrated worlds.

Formally, embedding is considered a syntactic subordination which, together with linking and alternation, represents a means of combining sequences into complex forms. When referring to narrative texts, embedding generates a narrative subordination which is used for distinguishing between the frame narrated world and narrated world, both being included in the whole fictional world. The narrative relationship between the narrative worlds inside the same frame narrated world may be further developed vertically, horizontally and both. The dichotomy between *le discours* and *le histoire* proves to be useful for identifying the relationships between the narrative instances in framed stories. Based on a concentric structure, a frame story which is included in the general fictional world of the narrative text may contain several narrated worlds. Among the narrative instances belonging to these narrated worlds there are established certain relationships. At the same time, there could be developed relationships between the narrative instances belonging to these narrated worlds on one side and the frame narrated world that contains them on the other side.

In the case of the frame *homodiegetic* narrative, the first person pronoun and perspective are used by both the character-narrator and the character-actor and this fact is creating the possibility of extending his/her ideological position from the frame story into the narrated world(s). Following the theory of possible worlds not only for the frame narrated world but also for the narrated world(s) it may contain, the connections between the narrative instances could be described according to the use of the first-person pronoun and perspective. Either they mark the character-narrator's discourse or the character-actor's discourse they change their functions according to the narrated world they belong to. Considering discourse as an illocutionary category and story as an ontological category, the changing position of the first-person pronoun and perspective which imply the changing of their functions may give a more dynamic aspect to the whole fictional world. Considered static, the system of narrative frames has been completed with the notion of *stacks* which refers to the sequential ordering of levels in texts having the possibility of boundary

---

<sup>1</sup> The notion of narrative level was introduced by Gérard Genette as one of the three categories forming a narrative situation, the other two being the time of narrating and person.

crossing. Usually the building and un-building of a stack follows a strict protocol<sup>1</sup> that restricts the range of narrative operations. Far from being constrained by the conditions of narrating, the fictional text may subvert the mechanism of stack, taking an alternative stance, developing different narrative operations such as the endlessly expanding stack, strange loops or contamination of levels and so on. (Ryan, 1991: 188-189)

In functional terms, the organisation of stacks may follow a *horizontal embedding* of narrative material, when a story is narrated by at least two character-narrators without changing the diegetic level, or a *vertical embedding* of the narrative material, when the act of narrating implies a change of level and of character-narrator and/or of character-actor. (Nelles, 1997: 127-143) The first-person embedded narrative represents the possibility of developing relationships between the narrative instances belonging to different narrative levels not only from a static perspective but also from a dynamic one, when the same character-narrator changes his/her ideological position crossing the boundaries of the frame narrated world into one, two or several narrated worlds. Either the embedding is horizontal or vertical the narrative perspective is adapted to the position of the character-narrator inside a narrated world but readjusted when the character-narrator becomes a character-actor inside another narrated world. The change of ideological position requires the change of narrative perspective which, in its turn, requires the change of the implicit imaginary generated by each character-narrator or character-actor.

### The Implicit Imaginary

The field of imaginary is in close connection with everything that does not belong to the actual reality, being made of all representations that exceed the limit of direct experiences and the logical deductions ascertained by them. (Patlagean, 1978: 249) Using Wolfgang Iser's triad of real-fictive-imaginary, in which the real is generated by the elements belonging to the referential reality and the fictive is regarded as an operational mode of consciousness that makes inroads into existing versions of the world, the imaginary needs outside influences so that it may become active. (Iser, 1993: xiv) The act of fictionalizing<sup>2</sup> creates the opportunity for the imaginary to be activated, leading the real into the imaginary and the imaginary into the real, crossing the boundaries of what it organizes, recognized as external reality, as well as of what it converts into a *gestalt*, meaning the diffusiveness of the imaginary. (*Ibidem* 4) The entire process makes the fictive to be the perfect medium for the imaginary to develop itself. In the case of frame narratives, the whole fictional world provides the basic background for the imaginary to be activated and led by each narrative instance. Crossing the borderlines between the embedded narrated world and the one, two or several narrated worlds, the imaginary activated by the character-

---

<sup>1</sup> Such a protocol requires that narrative levels be kept distinct, that they be pushed or popped on the top of the stack exclusively, that pushing and popping be properly signaled, that every boundary be crossed twice, once during the building and once during the un-building of the stack. This protocol is respected by all standard narrative text but not by all texts of literary fiction. (Ryan, 1991: 187)

<sup>2</sup> Through a fictionalizing act, certain items selected from extra-textual realities are reproduced in the text in order to endow it with aims and experiences that do not belong to reality that is reproduced. (Iser, 1993: 2)

narrator could be prolonged into the imaginary activated by the character-actor(s) adapting its ideological position each time. Being a mental product of the sensorial representations, distinct from the physical perception of actual realities and from the conceptualization of abstract ideas, imaginary contains all images not only perceived but also adapted according to its manner of perceiving reality. (Wunenburger, 1991: 3) In other words, imaginary can represent specific items from the actual reality selected intentionally<sup>1</sup> by the consciousness according to Sartre's point of view, or by the psyche as in Castoriadis's philosophy or by the subject as in Coleridge's perspective, but either way, it reveals two major dimensions: the linguistic and the iconic. Both dimensions are to be found in the act of fictionalizing since each narrative instance is able to organize the external reality according to its ideological position, interests, attitudes, purposes and experiences and also to convert such a reality into a sign. Inside a first-person embedded world, the projection of the imaginary from the frame narrated world into the narrated world(s) may be vertical, horizontal or both, crossing the boundaries of narrative levels and also extending through the act of fictionalizing the imaginary activated by the narrator of the fictional world which implicitly presupposes the imaginary activated by the character-narrator of the frame narrated world as well as the imaginary activated by the character-actor(s) belonging to the narrated world(s). In doing so there could be identified different types of embedding according to the implicit imaginary that is developed not only in the act of fictionalizing but also in the process of narrating.

In the case of vertical embedding the *core implicit imaginary* is activated in both the narrated world and the frame narrated world that includes it as it may be noticed in Figure 1.

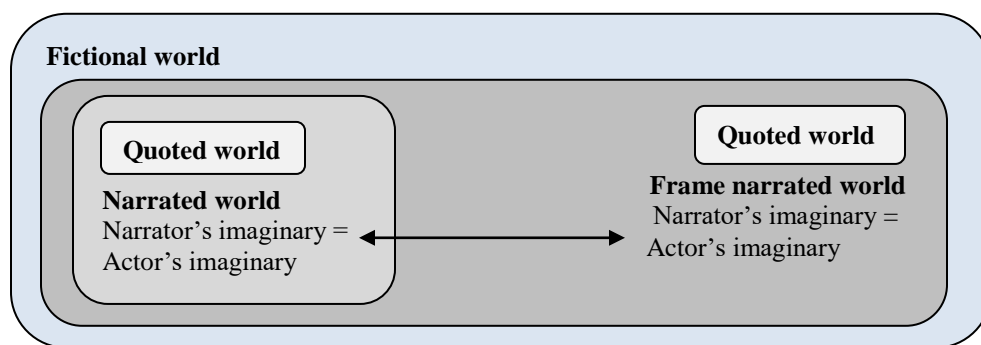

Figure 1

The character-narrator is not changed but the levels of actual reality are. Thus, the character-narrator moves from the frame narrated world into the narrated world which represents another actual reality. Either this inserted reality belongs to a dream, as in Lewis Carroll's *Alice in Wonderland*, or it represents fragments from a past reality, as in Tolstoy's *Kreutzer's Sonata*, it creates the context for the character-narrator to become character-actor and to fulfil the performing function too. There are situations when the frame narrated world contains two narrated worlds. The character-narrator belonging to the frame narrated world

<sup>1</sup> The intentional character of such a selection could be given by the fact that imaginary in general represents a projection of a consciousness.

extends his/her implicit imaginary into the narrated worlds but, this time, although the character-actor seems to be changed in the beginning, till the end, he/she proves to be the same. Each narrated world represents the narrative level for a different character-actor to activate his/her imaginary as well as to generate connections between them as it was illustrated in Figure 2.

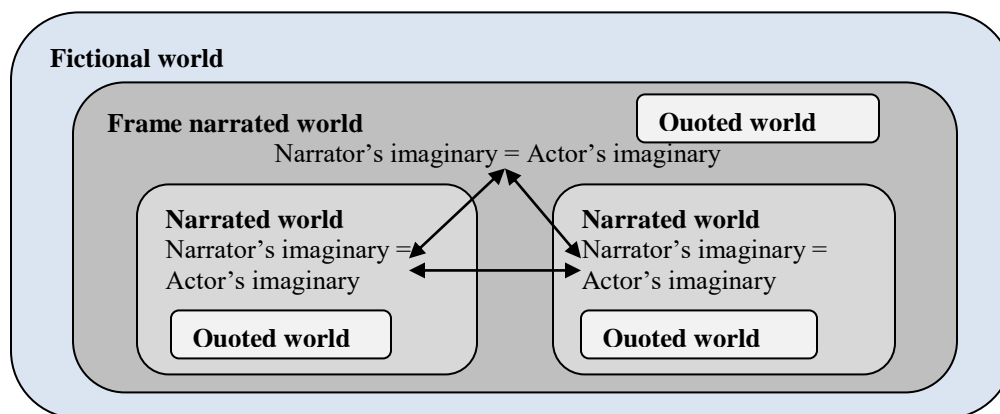

Figure 2

Trying to find a solution for the character-actor's identity problem, Max Frisch is introducing two different narrated worlds in his *Stiller* but, when the American James Larkin White, the character-actor of one of the stories, is taken as the Swiss Anatol Ludwig Stiller, the character-actor of the other story, it seems impossible to distinguish their identities. The implicit imaginary that was activated by the character-narrator belonging to the frame narrated world is prolonged into both narrated worlds where the *reversed implicit imaginary* generates connections not only on a vertical direction, as in the previous situation, but also horizontally between the two narrated worlds. Going further, these narrated worlds inserted into a frame narrated world may represent temporal divisions, into the past as well as into the future, as in Kurt Vonnegut's *Slaughter House 5*. Here, the character-narrator of the frame narrated world, Billy Pilgrim, an optometrist in New York, makes insertions<sup>1</sup> into a horrifying past in Dresden during the Second World War as well as into a distant future on the planet of Tralfamadore. The frame narrated world reveals the story of the present time and also represents the context for the implicit imaginary to be activated. The story of the past together with the story of the future are narrated worlds included in the frame story to which they are related. At the same time, they also embody proper contexts for prolonging the implicit imaginary. This time, the *related implicit imaginary* may be developed both vertically and horizontally but having the same character-actor, the element that relates the frame narrated world of the present with the two narrated worlds, that of the past and that of the future, as well as these two narrated worlds between

<sup>11</sup> All these insertions may be regarded as means of escaping reality as well as useful remedies against the hostile existence of the human being.

them. The difference from the *core implicit imaginary* is given by the complex process of embedding which is now on two directions and from the *reversed implicit imaginary* by the common identity between the character-actors of the narrated worlds but the manner of embedding is the same as in Figure 2. When the narrated worlds are more than two, the implicit imaginary activated by the character-narrator in the frame narrated world may be extended to all the narrated worlds. The connections between the frame narrated world and the narrated worlds it contains together with the connections between the narrated worlds are similar to those of the *related implicit imaginary* but this time the number of narrated worlds is multiplied as it could be seen in Figure 3<sup>1</sup>.

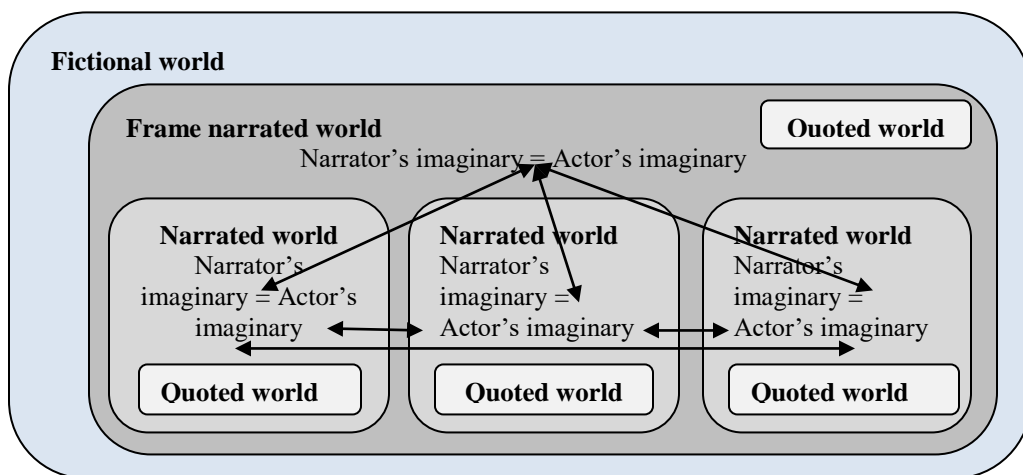

Figure 3

In a collection of ten unfinished stories, Italo Calvino in his *Se una notte d'inverno un viaggiatore* proposed a fictional world that could be received and analysed in an unlimited number of ways. Following the manner of activating the implicit imaginary in the frame narrated world, the character-narrator is now involved in a narrative relationship with another type of character that was impersonated by the character-reader so that another perspective of narrative analysis could be investigated here, but taking into account only the character-narrator's implicit imaginary activated in the act of fictionalizing the extension of it may be multiplied in as many narrated worlds as they are. For all ten unfinished narrated worlds, the character-narrator keeps using the first-person pronoun and perspective but for the developing the relationship with the character-reader, the character-narrator chooses to use the third-person pronoun and perspective thus involving the character-reader in the act of narrating as well. Focusing only on the first-person pronoun and perspective, the relationship between the character-narrator and the character-actors of all ten unfinished narrated worlds creates a proper context for the implicit imaginary to be activated, crossing the narrative boundaries. In this case, the embedding is both vertically and horizontally, the

<sup>1</sup> This figure exhibits only three narrated worlds but the number could be unlimited according to the narrative they belong to.

only difference between this *multiple implicit imaginary* and the *reversed implicit imaginary* as well as the *related implicit imaginary* stands in the number of the narrated worlds that generates the opportunity for the implicit imaginary to be activated on a second level of embedding. All four implicit imaginaries, *core*, *reversed*, *related* and *multiple*, represent possibilities for activating and prolonging the implicit imaginary from the frame narrated world into the narrated worlds it contains. The more narrated worlds are involved the more complex the relationships among the narrative instances are as well as the manner of embedding which becomes more complex too, from vertical only to vertical and horizontal.

## Conclusion

Knowing that the structure of imaginary placed in a narrative text depends on the perspectives generated by the narrative instances belonging to that fictional world, the relationships developed among these instances are based on their narrative functions. In *homodiegetic* as well as in the *heterodiegetic narratives* the narrative functions may be changed among the narrative instances. In the case of frame stories, the narrative levels are disposed on concentric structure containing the frame narrated world which may include one or several narrated worlds. In the process of fictionalizing, the narrative imaginary may be activated by the narrative instances of character-narrator and of character-actor and prolonged from the frame narrated world into the narrated world(s) crossing the boundaries between the narrative levels and embedding the narrative material not only vertically but also vertically and horizontally. All types of implicit imaginary, *core*, *reversed*, *related* and *multiple* stand for possibilities of developing the structure of relationships among the narrative instances and they may be included in a narrative typology of activating and embedding the implicit imaginary.

## Bibliography

- Barthes, Roland, « Introduction à l'analyse structurale des récits » in *Communications*, no. 8, Seuil, Paris, 1966, 1-27
- Booth, Wayne, *The Rhetoric of Fiction*, The University of Chicago Press, Chicago, 1961
- Doležel, Lubomir, *Narrative Modes in Czech Literature*, University of Toronto Press, Toronto, 1973
- Genette, Gérard, *Figures III*, Seuil, Paris, 1972
- Greimas, Algirdas Julien, « Les actants, les acteurs et les figure » in C. Chabrol (ed.) *Sémiotique narrative et textuelle*, Larousse, Paris, 1973, 161-176
- Iser, Wolfgang, *The Fictive and the Imaginary: Charting Literary Anthropology*, The John Hopkins University Press, Baltimore, 1993
- Nelles, William, *Frameworks: Narrative Levels and Embedded Narrative*, Lang, New York, 1997
- Patlagean, Evelyn, « L'histoire de l'imaginaire », in Jacques Le Goff, Roger Chartier and Jacques Revel (eds.) *La Nouvelle histoire*, Editions Retz, Paris, 1978
- Ryan, Marie-Laure, *Possible Worlds, Artificial Intelligence, and Narrative Theory*, Indiana University Press, Bloomington, 1991
- Todorov, Tzvetan, « Les catégories du récit littéraire », in *Communications*, no.8, Seuil, Paris, 1966, 125-151
- Wunenburger, Jean Jacques, *L'Imagination*, PUF, Paris, 1991