

ON THE SYNTAX OF ROMANIAN DEFINITE PHRASES: CHANGES IN THE PATTERNS OF DEFINITENESS CHECKING

ALEXANDRA CORNILESCU¹ & ALEXANDRU NICOLAE²

University of Bucharest¹ & “Iorgu Iordan – Al. Rosetti” Institute of Linguistics, Bucharest²

Abstract

We discuss a type of variation in the pattern of definiteness valuation in Old Romanian (XVIth to XVIIIth century), which has never been noticed before, and examine its significance for the evolution of the DP. In Old Romanian, the suffixed definite article variably occurs *either on the first or on a lower [+N] constituent* (noun or adjective), so that an indefinite adjective may precede the definite noun. In contrast, in Modern Romanian, it is always the first noun which bears the definite article, while, in case an adjective precedes the noun, the definite article occurs on the adjective. The existence of this lower (definite) article raises several questions (the contexts where it occurs, its significance for the emergence of the enclitic definite article, etc.), to which this paper provides tentative answers. We propose that the existence of a lower definite article combined with a tendency for economy made possible the extension of the use of the article to (pre-nominal) adjectives, gradually leading to stricter conditions in the valuation of definiteness in Modern Romanian (Local Agree). At the same time, the lower article is evidence that the Romanian enclitic definite article originates in a post-posed demonstrative.

1. Aim of the paper. Theoretical assumptions

1.1 The problem

It is well known that in Modern Romanian (=MR) the definite article *-(u)l* is a suffix whose position is fixed: it always occurs on the *first* N(oun) or A(djective) in the group. This distribution is illustrated in (1):

- | | | | | |
|-----|----|--|----|--|
| (1) | a. | <i>fata frumoasă</i>
girl.the beautiful
'the beautiful girl' | b. | <i>frumoasa fată</i>
beautiful.the girl
'the beautiful girl' |
| | c. | * <i>fată frumoasa</i>
girl beautiful.the | d. | * <i>frumoasă fata</i>
beautiful girl.the |

In Old Romanian (=OR), however, the definite article variably occurs *either on the first N or A*, or *on a lower N*, so that another nominal constituent, for instance, an (indefinite) A, may precede the definite N:

- (2) OR: *spre ticăloase cuvintele mele audzul îți pleacă...* (Cantemir)
to vicious words.the my hearing your turn
'Lend your ear to my vicious words.'
- (MR: *spre ticăloasele cuvinte ale mele audzul îți pleacă...*)

This type of variation has never been noticed before. It is the *aim of this paper* to explore it and to examine its significance for the evolution of the Romanian DP. The article which appears on a constituent different from the first N or A will be referred to as “the lower article” for convenience.

Before describing the lower definite article, it is appropriate to present our assumptions regarding definiteness checking in MR, so as to later identify the source of the contrast between the two stages in the evolution of the DP.

1.2. Theoretical assumptions

1.2.1 Definiteness as an *(un)interpretable feature*

It is likely that in UG, the D head is *uninterpretable* [φ] and *interpretable definite* (i.e., [$u\varphi$, $i\text{def}$]), since, in as much as it is interpretable, definiteness is tied to “referentiality”. Thus, definite DPs (proper names, pronouns, definite and demonstrative descriptions) have *determined reference* (Farkas & von Stechow 2003, Farkas & de Swart 2007), requiring *unique discourse referents*. From a syntactic perspective it is the D-layer which secures argumenthood (Stowell 1989, Longobardi, 1994, Giusti 1996, 2005, Borer 2005). From a semantic perspective, in theories like DRT (Kamp & Reyle 1993, and references above), in a D + NP structure, it is the D which introduces the (unique) discourse referent, while the NP supplies a descriptive predicative condition.

Following the theoretical suggestions of Pesetsky & Torrego (2007) on the syntax of valuation, definiteness will be considered a nominal property, uninterpretable on the noun ($[u\text{def}]$) and interpretable (though *unvalued*) on the determiner ($[i\text{def}]$). Yet, definiteness **may be valued** on certain types of nouns, i.e., certain categories of nouns may be marked as $[u+\text{def}]$ from the lexicon. In UG, proper names are inherently $[+\text{definite}]$ and value the $[i\text{def}]$ feature of D, as proposed in Longobardi (1994). Similarly, we propose that in languages where nouns morphologically vary for definiteness, like Romanian, nominal morphology *may* supply the value of the definiteness feature in D.

Concluding, definiteness in D is interpretable and unvalued $[i\text{def}]$, and it will be valued either by external merge of a lexical determiner or by internal merge of an NP/DP which is morphologically definite, such as a noun suffixed by the definite article. Assuming that feature valuation is consequent upon external merge of the article, definiteness valuation for a language that has free-standing definite determiners like English might look like the following:

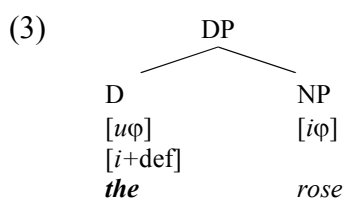

The D head agrees with the N head valuing its φ -features. At the same time, the definite article values the $[i\text{def}]$ feature of the D head.

In agreement with other analysts, we assume that in MR, the enclitic article *-(u)l* is a suffix (cf. Ortman & Popescu 2000 among many.), subcategorized for an N—/A—complement, with which it merges in the lexicon:

- (4) a. *trandafirul* (*frumos*)
 rose.the (beautiful)
 “the beautiful rose”
- b. *frumosul trandafir*
 beautiful.the rose
 “the beautiful rose”

Let us detail the mechanism of definiteness valuation. When the N is suffixed with the definite article, the result is a definite noun, therefore *an NP which is valued for definiteness*, marked [*u+def*, *iφ*]. These features of the N are used to value the corresponding interpretable (but unvalued) features of the D head, as shown below:

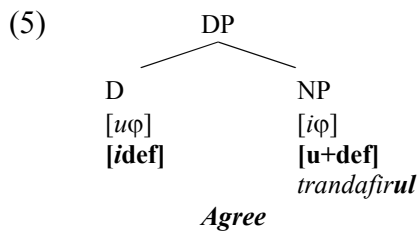

As mentioned, the definite article may also be suffixed to an A-head. Importantly, MR As may be suffixed with the definite article only when the AP is *attributive* and *pre-nominal*; in such cases, the A merges as a *specifier of the NP*, so that the adjectival head is in a configuration of local Agree with the NP:

- (6) *frumosul trandafir*
 beautiful.the rose
 “the beautiful rose”

When the A is predicative (e.g., a post-copular predicative (7a) or a post-nominal adjunct (7b)), the definite article is impossible:

- (7) a. **Trandafirul este frumosul.*
 rose.the is beautiful.the
- b. **trandafir(ul) frumosul*
 rose(.the) beautiful

1.2.2 Locality of Move and Agree in Modern Romanian DPs

Definiteness is therefore an *agreement feature* for A. We assume that MR As, by virtue of being ϕ -complete, may also bear an [*udef*] feature which is never valued by As themselves, but may be valued by a definite N. The A probes the nominal that it c-commands and will agree with the N in definiteness and ϕ -features, so that the A, which enters the derivation [*uφ*, *udef*], may end up being [*uφ*, *u+def*], its features being thus identical with the N's. When this happens, phonology always realizes [*u+def*] on the *highest* copy below D, i.e., the highest N or A below D, which will bear the definite article at PF. This highest copy is the one that values the [*idef*] feature of the D head. The process of definiteness feature transmission assumes the form of a series of Agree relations ((8b), (8c)); finally, the definite A immediately below D values the [*idef*] feature of D (8c).

- (8) a. *frumosul trandafir*
 beautiful.the rose
 “the beautiful rose”

We conclude that in MR, it is the first [+N] constituent (N or A) of the DP which values the feature in D, by *Local Agree*. Romanian and French contrast with English in the following modifier + proper name structure:

- (12) a. *le vieux Paris*
the old Paris
“old Paris”
c. *old Paris*
- b. *vechiul Paris*
old.the Paris
“old Paris”

Unlike the two Romance languages, English allows *Long Distance Agree (LDA)*, in the sense that the N which values the feature in D may be separated from D by an intervening adjective. French and Romanian disallow LDA, but use alternative strategies to value definiteness: a free standing definite article (French) or a definite article suffixed on an A immediately below D (Romanian).

Locality of Move For the analysis that follows, it is also important to mention one more property of the MR DP related to the post-nominal Dem(onstrative) and, more generally, to the application of DP-internal Move. We claim that Move, like Agree, is *local*; it cannot cross a higher specifier. As to demonstratives, like Spanish, MR disposes of both pre-nominal (13a) and post-nominal Dems (13b). The former are similar to their Romance counterparts and need no discussion. The latter have special locality constraints, namely the post-nominal Dem can only be preceded by a definite N, strictly adjacent to it (13b) (see the ungrammaticality of (13c) and (13d)).

- (13) a. *acest (foarte) frumos portret*
this (very) beautiful portrait
“this (very) beautiful portrait”
c. **portretul (foarte) frumos acesta*
portrait (very) beautiful this
- b. *portretul acesta (foarte) frumos*
portrait this (very) beautiful
“this (very) beautiful portrait”
d. **(foarte) frumosul acesta portret*
(very) beautiful this portrait

Strict adjacency of the post-nominal Dem to the definite head has standardly been interpreted as an instance of definite N⁰-Movement to D across a phrasal Dem in the specifier below D, as shown in the intermediate configuration (14) (cf. Cornilescu 1992, Vulchanova & Vulchanova 1998 among many).

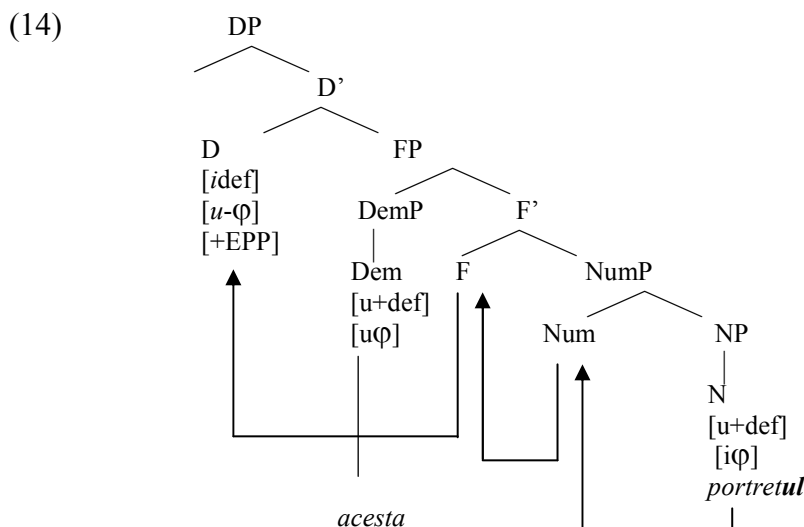

The examples in (13) show a sharp contrast between APs and NPs in the demonstrative construction. In contrast to definite Ns, definite As cannot move across the DemP, as known since Grosu (1988). In MR, As always move as phrases (14d) and, if Move is local, APs cannot move past the demonstrative specifier. This raises the issue of why N-Raising is possible, while AP-Raising is not. Notice that the DemP and the definite NP/AP share their [ϕ] and [+def]-features, which makes them equally good goals for the probe in D. Consequently, it is the DemP which is closer to D that should value definiteness. This is what blocks the raising of the AP, as expected. Once again, the definite NP and the DemP are equally good goals for probe in D, *but* the N-head is lighter and as such is preferred as a mover. The preference for N⁰-Movement thus follows from a principle of economy which requires piping only as much material as is necessary for convergence (*Pied Pipe Less Weight* – Stateva 2002, or *Attract/Move Smallest* – Akiyama 2004). The N successive-cyclically moves crossing the DemP and ending up in D.

Conclusion What has been said so far proves that the syntax of the MR DP shows *locality* constraints on both Agree and Move.

2. Long Distance Agree in Old Romanian

2.1 *The Lower Definite Article*

Against the background sketched in Section 1., we may now turn to the *variation in the pattern of definiteness valuation* in OR (XVIth to XVIIIth century), which we mentioned above and which has gone unnoticed so far; no mention of it is made of it in important histories of Romanian (Gheție 1975, Rosetti 1968, Densusianu 1961, Dimitrescu, 1978, Brancuș 2004, Niculescu 1990). In OR, the definite article variably occurs *either on the first [+N] constituent or on the head N in a lower position*; another nominal constituent, for instance, an A, will precede the definite N in such cases:

- (15) *ca mare scârșnetul roatelor* (Cantemir)
 like great grinding.the of the wheels
 ‘like the strong grinding of the wheels’

Examples of this type show that *locality conditions are not so strict* in OR, allowing a different pattern of definiteness checking:

- (16) *Definiteness valuation in Old Romanian – Long Distance Agree (LDA)*: The goal that values the probe in D is a c-commanded nominal phrase (NP, AP) which need not be the first (nominal) phrase c-commanded by D.

This amounts to saying that the [+def] feature is realized either on the first or on a lower nominal constituent of the DP. The definite article which shows up on a N which is *not the first constituent* of the DP is what we have called the “*lower definite article*”.

2.2 The extension and range of the Lower Definite Article

The lower definite article is present from the oldest Romanian texts of the XVIth century up until the first half of the XVIIIth century. This phenomenon thus belongs to OR, as opposed to MR, assumed to start at the end of the XVIIIth century (cf. Gheție 1975):

- (17) a. ...*au venit egumenul de Bistrița cu cinstită cartea mării tale* (XVIth – DÎR)
has come abbot.the of Bistrița with honoured letter.the highness.the_{Gen} your
“...the Abbot of Bistrița came with your highness’ honoured letter”
- b. *au aflat cap și începătura moșilor [...] ca să nu se înece*
(they) had found head and beginning ancestors.the_{Gen} so that not be drowned
a toate țările anii trecuți (XVIIth, 1641 – Ureche)
of all countries.the years.the passed
“They found the origin and the beginning of their ancestors so that the passed years of all countries may not be drowned into oblivion”
- c. *plecat robul Măriei Tale*, Radu logofăt... (XVIIth, 1688 – *Biblia*)
humble servant.the highness.the_{Gen} Your, Radu Chancellor
“your highness’s humble servant, Radu Chancellor”
- d. *Umblăm după a lumii înșelătoare față* (XVIIth, 1671 – Costin)
Go we after AL_{genitival article} world’s deceitful face.the
“We are after the world’s deceitful face”
- e. *Așa, fără veste el în vrăjmași colțișii crocodilului aflându-se* (XVIIIth – Cantemir)
thus suddenly he in inimical teeth.the crocodile.the_{Gen} being
“Thus, suddenly, he was in the crocodile’s inimical teeth”

As to the range of the constituents that may precede the lower definite article suffixed on the N, they may be of two types: As and pre-nominal genitives (**Gens**).

(A) an (indefinite) adjective

- (18) *Așa, fără veste el în vrăjmași colțișii crocodilului aflându-se* (Cantemir)
thus suddenly he in inimical teeth.the crocodile.the_{Gen} being
“Thus, suddenly, he was in the crocodile’s inimical teeth”

(B) Gen Phrase (Gen DP)

- (19) ...*ca să nu se înece a toate țările anii trecuți* (Ureche)
so that not be drowned of all countries.the years.the passed
“...so that the passed years of all countries may not be drowned into oblivion”

One should know that in MR a pre-nominal Gen is followed by an indefinite N. Just as in English, a DP containing a pre-nominal Gen is interpreted as [+def], and it is the pre-nominal Gen DP which checks the [*idef*] feature of the DP. The pre-nominal Gen DP in MR functions as a definite Determiner Gen (Huddleston & Pullum 2002). It also occurs in the first position of the DP, presumably in [Spec, DP].

- (20) a. *al regelui fiu* b. *fiul regelui*
AL_{genitival article} king.the_{Gen} son son.the king.the_{Gen}
“the king’s son” “the king’s son”

Examples like (19) contrast with MR (20a), and are no longer found in MR.

The lower definite article raises several questions: 1. What is the interpretation of this phenomenon in the framework sketched above? 2. What made the lower article likely or possible in OR? 3. What are the contexts that favored the occurrence of the lower article? 4. What are the causes that led to the elimination of this pattern? 5. Are there other OR DP structures which relate to the existence of LDA? In the following sections of the paper we supply tentative answers to these questions.

2.3. Interpreting the facts of Old Romanian in the framework sketched in Section 1

Two morpho-syntactic properties of Romanian N/A have combined to produce the strict locality conditions on definiteness valuation in MR. The first is the suffixal nature of the article which allows Ns to be valued for definiteness, even if their definiteness feature is uninterpretable (i.e., [*u*+def]). The second significant property is that, at some point in the evolution of Romanian, As must have acquired the possibility of *optionally* incorporating an uninterpretable unvalued definiteness feature [*u*def]. This feature was valued through Agree with the N, as shown above. Since Agree was *long distance*, and the nominal valued for definiteness did not need to be the first NP/AP below D, we expect the following alternations in OR, all of which are attested:

(i) The definite article shows on the first NP or AP of the DP (the MR pattern, available in all attested stages of Romanian)

- (21) *au purces fără numai din vechea și rânceda pizmăluire* (Cantemir)
 (it) happened only out.of old.the and rancid.the envy
 “It all happened out the old and rancid envy”

(ii) The definite article shows on an NP which is not the first phrase of the DP (this is the lower article)

- (22) *spre ticăloase cuvintele mele audzul îți pleacă...* (Cantemir)
 to vicious words.the my hearing your turn
 ‘Lend your ear to my vicious words’

(iii) Sporadically, the definite article could also be present on more than one constituent, i.e., the DP shows *multiple definites* (cf. Croitor 2008). This is consistent with the view that definiteness had become a *concord features* in OR, and Romanian morphology allows it to be uninterpretable but *valued* and realized on both Ns and As. Multiple definites are present both in the order A+ N (examples (23), from Croitor 2008), and in the order N+ A (examples (24), likewise from Croitor 2008); apparently, multiple definites were lost (in these patterns) at the end of the XVIIIth century:

(A) Multiple definites: A+N

- (23) a. *Ce i-au tăiat atunci curând puternica mână lui Dumnedzeu zilele* (Costin)
 that to-him have cut then soon mighty.the hand.the of God days.the
 “God’s almighty hand took his/her days”

b. ...*moaștele a sfintei prepodobnei Paraschevei, în* (Costin)
 ...relics.the of saint.the beautifully-adorned.the Parascheva, in
 "...the relics of the holy, beautifully-adorned (Saint) Parascheva"

(B) **Multiple definites: N+A**

(24) *zidul cetății mari și frumoasei în Spania* (Cantacuzino)
 wall.the city.the.Gen big.the.Gen and beautiful.the.GEN in Spain
 "the wall of the big and beautiful city in Spain"

It is reasonable to assume that it was precisely *the possibility of valuing definiteness on pre-nominal As that led to stricter locality conditions on Agree*, that is, to the MR requirement that the constituent that values the [idef] feature of D should be the first AP/NP below D.

Gradually, as a result of a general tendency towards economy, the constituent that values [idef] in D (i.e, which has an LF effect) got to be the only one which *phonologically realizes definiteness*. This was either a definite pre-nominal A or a definite N. Multiple occurrences of the suffixal article are now ruled out. Moreover, only *pre-nominal As* are ever suffixed by the definite article, since only pre-nominal As can be closer to D than the N. Definiteness thus turns into an *exclusive property of attributive As* as opposed to predicative ones (see above). This means that As that merge as attributes (specifiers or pre-nominal adjuncts) are obligatorily specified as [udef]. This is what guarantees that if the head N is [u+def], and there is a pre-nominal A in the DP, definiteness will be realized on the pre-nominal adjective immediately below D.

3. What the Lower Article suggests about the emergence of the enclitic article

3.1 *An open question*

The account proposed above relies on the contrast between languages which value definiteness in D by merging a determiner and languages which value D by means of a lexical category morphologically marked as valued for definiteness. From a Romance diachronic perspective, one of the still hot puzzles is the manner in which the same Latin demonstrative *ille* (cf. Iordan & Manoliu 1965) led to proclitic free-standing articles in other Romance languages, but to an enclitic article in Romanian.

We claim that the lower article tilts the balance for the hypothesis that the enclitic article developed out of the post-nominal Latin Dem *ille* rather than out of a pre-nominal demonstrative, as in Giusti's analysis of the history of the definite article in Romance. Both proposals have been advanced for Romanian as well (see Renzi 1993 for the pre-nominal demonstrative hypothesis, and Coteanu 1956 and Graur 1967 for the post-nominal demonstrative hypothesis).

The lower article matters in this on-going debate, since it is the so far only attested construction that does not show the Romanian definite article on the head of the first NP/AP of the DP. The standard "high article" is consistent with analyses where the article merges in D and is lowered on the first [+N] constituent (as recently proposed by Dobrovie & Giurgea, 2006), or where the article merges in D and there is movement into

the D-area (N-to-D, AP-to-Spec, DP) as assumed in older studies (Dobrovie-Sorin 1987, Grosu 1988).

The lower article should be construed as evidence that the article *merges low*, and “moves” higher through Agree reaching the position below D. The aim of this section is two-fold: we propose a possible path from the Latin post-nominal demonstrative to the enclitic definite article; secondly we argue that, if correct, the diachronic proposal is consistent with an analysis of the enclitic article as a suffix rather than a (second position) clitic.

Before detailing the change from post-nominal Dem to enclitic definite article, we spell out our (minimal) hypotheses regarding the architecture of the DP. Following a number of researchers (Borer 2005, Giusti 1993, Julien 2005, Roehrs 2006), we assume that articles, or rather, determiners, merge lower, say in an Art(icle)P (valuing the [ϕ] and [*i*def] features of the Art head), and then move to D or [Spec, DP] to value the features there (deixis, specificity, definiteness, [*u* ϕ]), if we assume, as mentioned above (cf. also Giusti 1993, Longobardi 2001) that an argument DP is interpretable only if its D projection is visible. The space between DP and ArtP may (but need not) host periphery or quantificational projections, as in the proposal put forth by Roehrs (2006):

(25) DP > CardP > ArtP > NumP > NP

It follows that the Dems merge in Spec, ArtP, under the assumption that they are phrasal. We also accept that pre-nominal As in Romance merge as specifiers of functional projections (Bernstein, 1991, 1993), while post-nominal As merge as adjuncts (Giurgea 2008). As shown, MR relies on LA and Local Movement. OR appears to have employed LDA (checking of a feature across an intervening specifier), and Long Distance Movement (movement over a relevant specifier).

In agreement with proposals for Scandinavian (see especially Roehrs 2006: 49-64) and Romance (Renzi 1993, 1997, Lyons 1999, Giusti 1998), we might envisage the following scenario for the rise of the enclitic article. The enclitic article emerged through the reanalysis of the Dem *ille* in the context of the *post-nominal Dem construction*; reanalysis amounted to a change in its c-selection properties. This hypothesis is supported by the existence of post-nominal Dems in all written phases of Romanian (26):

(26) a. *Au trimis Paşa pre **tălmaciul acela*** b. *şi au căzut în **războiul acela***
 have sent Pasha PE translator.the that and have fallen (they) in war.the that
 “Pasha sent that translator” “And they fell dead in that war”
 (Costin) (Ureche)

The post-nominal position of As, possible in Latin, was reinforced by the contact with the local Dacian idioms, which strongly preferred to post-pose the A, including the (adjectival) Dem (Brâncuş 2004, Graur 1967). In all attested stages of Romanian, the pre-nominal or post-nominal position of the Dem depended on its textual, prosodic role (deictic or anaphoric). Consequently, it may be believed that either the NP or the DemP alternatively moved to [Spec, DP] to check the unvalued features there, thus deriving the alternative orders ((27a) and (27b)).

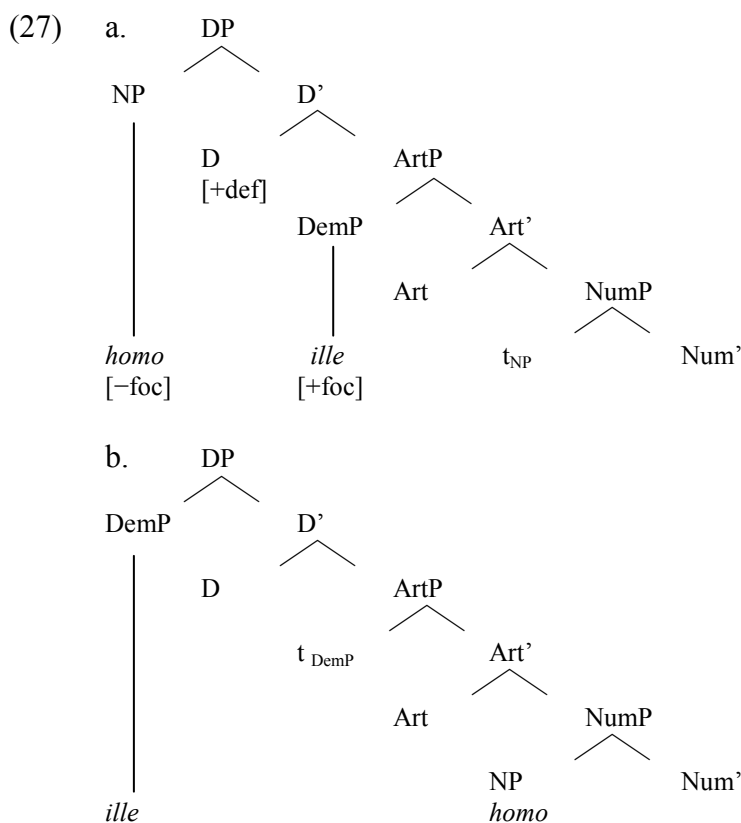

As known, in two-member structures like *omul acesta* ('man.the this') the post-posed Dem is normally *focused* (Bernstein 2001 a.o.), and may have a [locative-deictic] feature, while the Romanian pre-nominal Dem (*acest om* 'this man') is mostly anaphoric (Manoliu-Manea 1993). It is, then, more plausible to assume that the re-analysis of the Dem as an article occurred in a *three-term construction*, which would shift the nuclear stress on the last (most deeply embedded) third term (Cinque, 1993). Graur (1967) thus suggested as a basis for re-analysis the three-term construction: *homo ille bonus*, N + Dem + Adj. Since the Dem is not in focus, and thus probably not stressed, it is likely that it was "weakened" and **re-analyzed as a head** moving to D⁰ rather than to [Spec, DP], following the general evolution of Romance or Germanic (Roehrs 2006 for Scandinavian). It is true that, as remarked by one of the reviewers, since in the earliest Romanian texts the article is already fully grammaticalized, there is no decisive piece of evidence that re-analysis occurred in the three term structure. The demonstrative might perhaps have been distressed as a result of its anaphoric function in the simpler two-term construction as well. The change from a phrase to a head moving to the D-head position would have been the same. The often made suggestion that re-analysis is based on structures including post-nominal modifiers probably takes into account the fact that the definite article is still required to license a post-nominal modifier/argument in prepositional constructions, where the nominal head is otherwise determinerless (Isac 2006):

- (28) a. *Cartea este pe masă.*
 book.the is on table
 "The book is on the table"
- b. *Cartea este pe masa rotundă.*
 book.the is on table.the round
 "The book is on the round table"

Head movement of Dem to D frees [Spec, DP] for NP-movement; suffixation takes place in this Spec-Head configuration. Re-analysis of the Dem as a suffix represents a change of its c-selection feature, which becomes [+N---], satisfied by combining it with a nominal head (an N^0 , A^0 constituent). Head-adjunction of the Dem-article to the N causes the former to undergo phonological reduction, dropping its first syllable *ILLE* → *-(U)L*. Significantly, the pre-nominal definite article of French, which has developed out of a pre-nominal demonstrative (Jordan&Manoliu 1965, Giusti 1993, 1998), has also further developed from an independent head into a *prefix* in some of the creoles based on French (Mauritian Creole), being reanalyzed as part of the noun stem (Lyons 1999: 331; examples from Lyons 1999):

- (29) a. *le lit* (Standard French)
 the bed
 ‘the bed’
 b. *lilila* (Mauritian Creole)
 the.bed there
 ‘that bed’

The change from Dem to article also meant a loss of semantic features (bleaching), from the richer matrix of the Dem [(locative)-deictic, definite, anaphoric, 3rd/6th person, adjective, /pronoun] to the more reduced feature matrix of the article [definite, anaphoric, adjective] (cf. Giusti 1998, Lyons 1999).

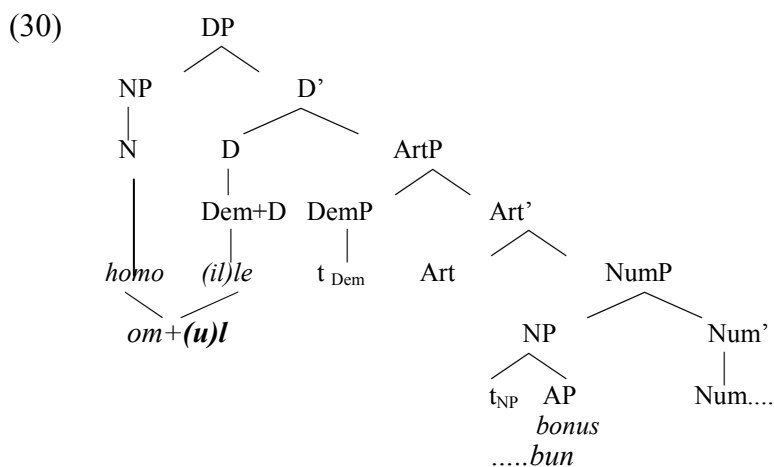

The lower article preceded by an A is a precious missing link in the chain leading from a post-nominal Dem to an article placed on the first nominal constituent of the DP. Thus Renzi (1993: 308), expressing skepticism about the post-nominal Dem hypothesis, was wondering: “Why starting from *omul bătrân* [man.the old ‘the old man’], we have *bătrânul om* [old.the man ‘the old man’], and not *bătrân omul* [old man.the]?” in other words why is there no evidence of an article on a lower term than the first? The examples that we have surveyed are exactly of the type expected by Renzi (1993) to occur under the hypothesis of deriving the article from the post-nominal Dem.

3.2 Consequences for the analysis of the article: the Romanian definite article is a *suffix*

The historical path suggested above is consistent with the claim that the combination of the article with the N or A is the outcome of a *morphological rule*, rather than the effect of *syntactic movement*; in particular, it is not the output of N-to-D or AP-to-Spec, D, as previously believed, since the important work of Dobrovie-Sorin (1987) and Grosu (1988). Strong evidence shows that the definite article is a *suffix* (Ortmann & Popescu 2000, Dobrovie-Sorin & Giurgea 2006, Tasmowsky 2009), *rather than a second position clitic / a Wackernagel clitic* (Renzi 1993). The morphologic status of the article as a *suffix* rather than a *clitic* follows from the following facts: (i) the article is not always in second position, since, inside the AP, degree words (and prepositions) may precede the A to which the article attaches, as in *atât de / foarte lungi+le drumuri* ('such of / very long.the roads'); (ii) the article attaches to both conjuncts in a coordination, as in *frumos+ul și mare*(+le) oraș* ('beautiful+the și big*(+the) city'), an unexpected repetition for a clitic (Zwicky & Pullum 1983); (iii) the article shows allomorphy, changing its form function of the last phoneme and the inflectional class of the stem; (iv) the article occurs in a constant position, i.e., on the *first* N or A in the DP. In contrast, Romanian clitics are inconsistent with respect to their position (since they may occur both before and after their syntactic host: *I-am luat/ am luat-o* 'him_{CL}-have_{AUX, 1st person} taken' / 'have_{AUX, 1st person} taken-her_{CL}'), as well as to the type of constituents they cliticize on (verbs, auxiliaries, Ns, complementizers).

4. Contexts of occurrence of the Lower Definite Article

A relevant question, already formulated above, is what contexts require or allow the use of a lower article. To answer this question, a body of texts ranging from the earliest Romanian writings of the XVIth century to the first half of the XVIIIth century was examined. The texts show *variation* between the 'high' article, used in most cases, and the 'lower' article. The lower article predominantly occurs when the definite head N is followed by another constituent (especially by a Gen(itive)). It is for modified and complemented (by a Gen) DPs that we have checked the *relative frequency* of the *high* vs. *lower* article (see (31) below).

(31)

Text	A _{DEF} + N + Gen DP (high article)	A + N _{DEF} + Gen DP (lower article)
Miron Costin	0	15
<i>Letopiseșul Cantacuzinesc</i>	3	1
R. Popescu	0	1
R. Greceanu	2	3
Constantin Cantacuzino	0	5
Cantemir	1	17
TOTAL	6	42
	High article: 6 (12,5%)	Lower article: 47 (87,5%)

The examination of the data shows that a lower definite article on N appears *overwhelmingly* (87,5%) in contexts where the head N is followed by a **Gen DP complement**. Other post-nominal modifiers may also sometimes trigger the presence of

the lower article as in (34). If there is no complement or modifier, the article emerges on the pre-nominal A, as in MR.

- (A) A[+def] + N[-def] (no complement/modifier)
- (32) *au purces fără numai din vechea și rânceda pizmăluire* (Cantemir)
 (it) happened only out.of old.the and rancid.the envy
 “It all happened out the old and rancid envy”
- (B) A[-def] + N[def] + GenDP
- (33) a. ...*ca mare scârșnetul roatelor* (Cantemir)
 like great grinding.the of the wheels
 “...like the strong grinding of the wheels...”
- b. ...*Corbul de uscate vinele goalelor ciolane clonțul și-ar ciocni* (*id.*)
 the Raven against dried-up veins.the empty.the_{Gen} bones bill hid would knock
 “The Raven might knock his bill against the dried-up veins of his bones.”
- c. ...*de dulce otrava Hulpii tare se amețiră* (Cantemir)
 ...with sweet poison.the of the Vixen much (they) got drunk
 “...they got quite drunk from the sweet poison of the Vixen”
- (C) A[-def] + N[def] + Modifier (PP or AP modifier)
- (34) a. *însă nu puține asuprele despre vrăjitorii vremii trasă* (Cantemir)
 but not few injustices.the from the magicians of the times (he) endured.
 “...but he endured many injustices from the magicians of the times...”
- b. *Neștiutor gândul omenesc [...] la ce merge..?* (Cantemir)
 Ignorant thought.the human what is heading for?
 “What is the ignorant thought of man aiming at?”

This distribution signals a tight relation between the inflectional Gen (and other modifiers) and the lower article, a fact which should be accounted for.

In MR, i.e., after 1780, the lower article disappears. There are, however, two types of motivated exceptions. The lower article is still part of religious and other obsolete texts (35), and in such case it is again mostly followed by the Gen. Secondly, there is a small group of quantificational or evaluative As that may function as *definite quantifiers*, and may or must be followed by definite Ns (see also GALR 2005, Barbu 2004): *întreg* (‘whole’), *singur* (‘unique’) *ditamai* (‘big’), *gogeamite* (‘big’), as in (36). No Gen modifier is required.

- (35) *Miluieste-mă, Doamne, după mare milă Ta!*
 Have-mercy-on-me God, according to great mercy.the Your
 “God, have mercy on me, according to your great mercy.”
- (36) a. *întreg orașul / întregul oraș* b. *ditamai prostul / *ditamaiul prost*
 whole city.the whole.the city big fool.the

We may *conclude* that one significant change in the syntax of the Romanian DP relates to the locality conditions of definiteness valuation. The definite feature strengthens requiring to be valued by a strictly local nominal constituent (N or A). Long Distance Agree is ruled out.

5. The (Lower) Article and the reorganization of the Genitive system

5.1 *The inflectional and the prepositional Genitive*

Romanian differs from other Romance languages in that it disposes of an inflectional Gen, while in other Romance languages the Gen is prepositional, marked by *de* ‘of’ (Grosu 1988 a.o.). The creation of a nominal inflectional Gen in Romanian was often viewed as an ‘effect’ of the suffixal definite article. Thus, an influential traditional opinion was that “in Romanian, the maintenance of oblique cases is the first and most important cause of the post-position of the definite article” (Coteanu 1956: 67). As also underlined by one of the reviewers, there is no demonstrable correlation between enclisis and the development of a inflectional Gen, or the other way round. It is true to say, however, that the development of the article system favored the reorganization of the Gen system: the Gen case has developed parallel, inflectional and prepositional forms (see (37)), and it is the suffixal article which varies for Case in Romanian. Thus not only did Romanian develop an inflectional Gen, as is well known, but the prepositional Gen, based on the same preposition DE as in all Romance, did not disappear, either. *Rather it became very limited and specialized* (see Cornilescu 2004 for details). In OR, the inflectional and the DE Gen are in free distribution (at least in post-nominal position where both occur) as shown by Pană Dindelegan (2008). Romanian has developed a *morphological distinction* between “anchoring Gens”, always DPs, and “non-anchoring (Prepositional) Gens”, always syntactic NPs (in the sense of Koptjevskaya-Tamm 2005), thus verifying the typological generalization that only languages that have articles may develop specialized forms for anchoring vs. non-anchoring Gen. The two forms show a very different cluster of morpho-syntactic and semantic properties, summed up below:

- | | | | | |
|------|----|----------------------------------|--------------------------------------|---|
| (37) | a. | <i>citirea</i> | <i>cât mai des</i> | <i>a autorilor clasici</i> |
| | | reading.the | more frequently | of classical authors |
| | b. | <i>citirea</i> | <i>frecventă de romane polițiste</i> | |
| | | reading.the | frequent of crime fiction | |
| (38) | | <i>Anchoring Gens</i> | | <i>Non-anchoring Gens</i> |
| | | | | (limited to nominalizations, see below) |
| | a. | inflectional | | a. prepositional |
| | b. | DP | | b. NP |
| | c. | referential, <e>-type denotation | | c. <e, t> denotation |

In sum, Romanian has developed a reliable syntax-semantics correlation in the domain of the Gen, by developing an inflectional Gen system alongside of the prepositional DE one.

5.2. *Significance of the statistical correlation between the Lower Definite Article and the inflectional Genitive*

As noticed in table (31), there is a strong statistical correlation between the lower article and the inflectional Gen.

This correlation may be interpreted from a double perspective:

(i) One may adopt a functional-pragmatic perspective, considering as significant the referential *interpretation* of the inflectional Gen, as opposed to the property, generic interpretation of the prepositional Gen. One might say that the lower article always accompanied that Gen form which served as a *contextual anchor* for the head. The article, initially a *post-posed Dem*, had a similar *anchoring role*, probably being interpreted as [locative-deictic] (Lyons 1999, Brugé 2000, Coteanu 1956, Manoliu-Manea 1993). The functional role of the post-posed article may have been that of a *weak Dem*, i.e., a form intermediate between a Dem and a definite article (Lyons 1999, Giusti 1998). It is the correlation between the anchoring role of the Gen and the presence of the post-posed Dem which is still visible in the lower N [+def] examples noticed above.

(ii) The correlation between the lower article and the post-posed inflectional Gen can also be viewed from a *more narrowly distributional perspective*, more likely to be the correct one. It is known that the inflectional Gen in Romanian is realized either by a bare inflected DP (= the **bare Genitive** (39b)), or as an inflected DP preceded by the **genitival article AL** (39a) (for a description of the Gen article see Cornilescu 1995, 2005). The two forms are in complementary distribution.

Roughly, the AL Gen occurs whenever the head N is indefinite (39a), while the bare Gen occurs when the head N is definite *and* the Gen is *adjacent* to the head N (39b):

- (39) a. *doi prieteni ai copilului*
two friends AL_{genitival article} child.the_{Gen}
“two friends of the child”
- b. *prietenul copilului*
friend.the child.the_{Gen}
“the child’s friend”

It is the syntax of definite DPs containing Gens that is of interest. With *definite* heads, the AL Gen occurs in two situations: (i) when there is an intervening modifier between the definite head and the Gen (40a); (ii) when the Gen *is* adjacent to the head, but the article is on a pre-nominal A (40b).

- (40) a. *prietenul bun al copilului*
friend.the child.the_{Gen}
“the child’s good friend”
- b. *bunul prieten al copilului*
good.the friend AL_{genitival article} child.the_{Gen}
“the child’s good friend”
- c. **bunul prieten copilului*
good.the friend child.the_{Gen}

Generalizing, the bare Gen occurs only when *it immediately follows a definite N*, while the AL Gen occurs *elsewhere*. The bare Gen is the preferred form since it is more economical (economy of representation). The preference for the bare Gen clearly must have been felt in OR as well. This is what explains the use of the lower definite article with inflectional Gen. If the article is placed on the N, instead of being placed on the

higher A, the Gen is adjacent to the definite article and it is possible to employ the more economical bare Gen (41a) (= 17a)), replacing the AL Gen (41b):

- (41) a. OR: *cu cinstită carteg mării tale* (Bare Gen)
 with honoured letter.the highness.the_{Gen} your
- b. MR: *cu cinstită carte a mării tale* (AL genitive)
 with honoured.the letter AL_{genitival} article highness.the_{Gen} your

Thus both formal economy considerations and functional semantic considerations may be invoked to account for the preference for the lower article in the context of an inflectional Gen.

6. Other OR DP patterns where *Agree* and *Move* operate *Long Distance*

In this section we show that the possibility of valuing the [*idef*] feature in D across a specifier, that is, LDA, was very general in OR and it combined with long distance move, therefore with movement across a specifier, a fact which is no longer allowed in MR. These hypotheses allow us to understand a number of other structures possible in OR, but systematically excluded in MR.

So far we have only examined cases where LDA is expressed by a lower article. There are, however, other constituents that may value D-definiteness, such as Dems or inflectional Gen DPs. In OR, these types of constituents could, like the definite article, value D-definiteness either by LA, or by LDA, i.e., at a distance from the D position. *Variation* in the pattern of definiteness valuation thus also had consequences for DPs that did not include the definite article, but which show Dems and Gen DPs in constructions no longer available in MR. In this section, we review some of these constructions which involve LDA or LD move.

6.1. As shown in Section 1., the post-nominal Dem cannot be preceded in MR by As. In contrast, in OR, both indefinite and definite As could precede the Dem. Consider indefinite As first:

- (42) a. OR: *cumplite aceste vremi de acum*
 terrible these times of now
 “these terrible times of now”
- b. MR: *aceste cumplite vremi de acum*
 these terrible times of now

The A in (42) is surely in an emphatic periphery position. As proposed by Laenzlinger (2005), periphery As merge or move to the left periphery of the DP defined by him as the space between a lower D_{Agreement} and a higher D_{Deixis}. This proposal is rather similar to Roehrs’s (2006) in (25) above, who also proposes that Agreement features are checked in ArtP, while ‘referential’/ deictic features are checked in the higher D position. Under these assumptions, an example like (42) would have the structure in (43): the Dem merges in [Spec, ArtP], the A is above it in a periphery projection, and the Dem checks its deictic feature across the A by LDA.

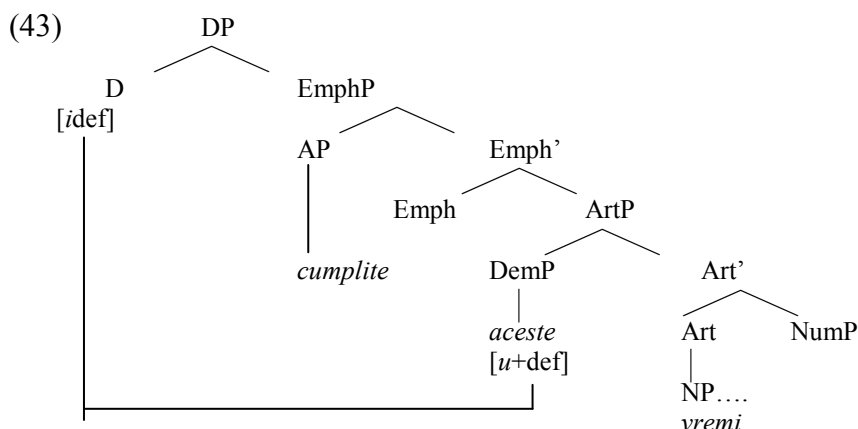

The absence of this pattern in MR is the result of the disappearance of LDA.

6.2 In OR, it is also possible for a complex definite NP to precede the Dem, contrary to MR, where the N^0 alone crosses the Dem (see section 1.).

- (44) a. *pă ticălosul pământu acesta să vie* (Greceanu)
 on wretched.the earth this come.Subj
 "...that he should come on this wretched earth.."
- b. *inima ta aceasta* (Greceanu)
 heart.the your this
 "this heart of yours"

The derivation of these examples involves movement of a phrase across a specifier, i.e., LDM. A relevant intermediate structure is the one in (45). Assuming that there is NP movement (at least) to NumP in Romance (cf. Cinque 2004 among many authors) the definite NP is in [Spec, NumP] functioning as a Goal for the unvalued [ϕ] and [def] features of the Art head. The Dem merges in [Spec, ArtP], valuing the features of the higher D, through LDA. The definite NP moves to [Spec, DP] presumably to avoid the focus interpretation. It is apparent that in moving to [Spec, DP], the definite NP crosses a phrasal constituent in [Spec, ArtP], this being an instance of LDM.

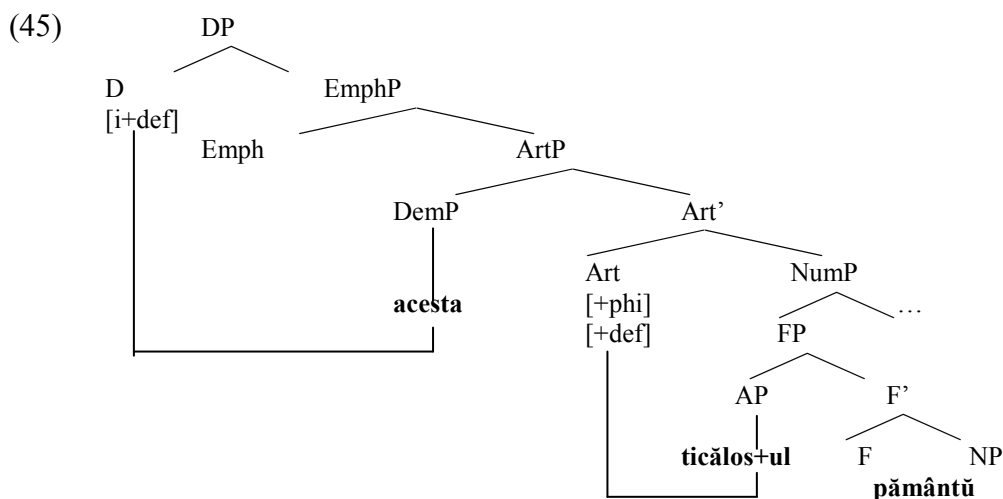

Expectedly, the structure in (45) is impossible in MR, where *Move* is strictly local. Notice also the examples below in (46), where a definite A alone has moved across the Dem, after checking definiteness against the ArtP head, as in (45) above.

- (46) a. OR: *nenorocitele acestea vremi* (Greceanu)
 unfortunate.the these times
 ‘these unfortunate times’
 (MR: *vremile acestea nenorocite*)

6.3 A second example of LDA in DPs that do not contain the definite article is offered by pre-nominal Gen DPs. With pre-nominal Gen DPs, as with Dems, definiteness is checked either at a distance or in a local configuration. First, there are DPs where the Gen is pre-nominal but is not involved in valuing definiteness. A definite determiner (the definite article, a Dem) or an indefinite one values the feature in D. In such cases, the pre-nominal Gen has nothing to do with the checking of definiteness (the valuer of the [*idef*] feature in D is the definite article (47a), the Dem (47b) or an indefinite determiner (48))

- (47) a. *ca să nu se înece a toate țările anii trecuți* (Ureche)
 so that not be drowned of all countries.the years.the passed
 “[...] so that the passed years of all countries may not be drowned into oblivion”
 b. *aceste ale Ciacalului cuvinte* (Cantemir)
 these AL Jackel.the.Gen words
 “these words of the Jackel”
- (48) *acele jigăanii, carele [...] într-altă a trupului parte arme [...] poartă* (Cantemir)
 those beasts, which [...] in other AL body’the.Gen part arms [] carry
 “those beasts which carry [] arms in some other part of their body”

Interestingly however, a Gen DP may incorporate a [+def] feature and represent the only definite constituent of the containing DP, checking definiteness by LDA, as in (49). In such cases, what matters is that the Gen DP is not in DP initial position, i.e., [Spec, DP], being preceded by periphery As, a structure impossible in MR.

- (49) a. *din cumplita vrășmășie frumos mirositoare a dragostei flori [...] a răsări*
 of cruel.the hostility sweet smelling AL love flower will spring
 “...the sweet smelling flower of love will arise out of that cruel hostility...”
 b. *însă și aceasta pre mai mare a viclesugului căptușală o făcea*
 yet and this PE bigger AL cheating hiding it_{CL} made
 ...but this she was doing to hide her cheating all the more.”
 (Cantemir)

In the same texts, however, a pre-nominal Gen DP may be in first position and is sufficient to trigger a definite interpretation of the containing DP, just as in English or in MR. This may be interpreted as an instance of LA. As already mentioned above in section 1., LA with the pre-nominal Gen is the only option of MR, examples (50) being syntactically perfect in MR.

- (50) a. ...*luându-se după a firii sale simțire* (Cantemir)
 ...taking-refl after of his nature feelings...
 ‘following the feelings if his own nature’
- b. *nici vă mierați de ale mele împleticite protase* (Cantemir)
 nor wander about AL my clumsy sentences...
 ‘Nor do you wonder about my clumsy sentences....’

Thus definiteness valuation across a specifier is a general option of OR for all constituents that could, in principle, value the definiteness feature in D.

7. Syntactic ambiguity and the loss of the Lower Definite Article

The co-existence of LA and LDA already mentioned above resulted in the occurrence of several systematically ambiguous structures. We briefly discuss two such cases.

7.1 The pre-nominal lexical Genitives

As shown in the previous section, the pre-nominal Gen could verify definiteness *locally* or *at a distance*, a phenomenon which could lead to interpretative ambiguities. Here is an example:

- (51) *raiul spândzurat cel ce din [șapte ale lumii minuni] unul ieste* (Cantemir)
 paradise.the suspended that which out of seven of the world wonders one is

Assuming the DP structure in (25) above and also that the pre-nominal Gen sits in a PossP analogous to the English determiner Gen, example (51) has the following two representations:

- | | | | | | | |
|------|----|-----------|-------|-----------------|-----------|------------|
| (52) | a. | DP [-def] | QP | PossP | ArtP/NumP | LA |
| | | șapte | șapte | ale lumii | minuni | |
| | b. | DP [+def] | QP | PossP | ArtP/NumP | LDA |
| | | | șapte | ale lumii[+def] | minuni | |

Representation (52a) is indefinite, “seven wonders of the world”; representation (52b) is definite, meaning “the seven wonders of the world”. (52b) involves *long distance valuation* of definiteness across the QP, while in (52a) the cardinal values the feature on D by means of LA. The *ambiguity* in the data made difficult for the interpreter to establish the type of (in)definiteness checking involved.

7.2 DP-internal inverted predicative adjectives

A second type of *ambiguity* regards the interpretation of pre-nominal As followed by the lower article. In the first place, these are attributive As in a LDA configuration. This is the only interpretation, for instance, after prepositions (53a). On the other hand, the indefinite A may be an emphatic inverted predicative A, originating in a Kaynean

small clause, and appearing at the periphery of the DP in a construction devoid of the copula, possibly as in (53b), or across the copula otherwise (53c).

- (53) a. ...*au venit egumenul de Bistrița cu cinstită carteḡ mării tale* (DÎR)
 has come abbot.the of Bistrița with honoured letter.the highness.the_{Gen} your
 “...the Abbot of Bistrița came with your highness’ honoured letter”
- b. *iar ascunsă giudéřul lui Dumnedzău toate gândurile oamenéřti le strămută* (Costin)
 and hidden judgment.the of God all thoughts.the human them_{CI} moves
 “and the hidden judgment of God moves all human thoughts”
 “and the judgment of God, being hidden, moves all human thoughts”
- c. *Iară lunecoasă sunt lucrurile războaielor si în puterea lui Dumnezeu stau.*
 And slippery are things.the of wars and in power of God stand (they) (Costin)
 “And the matters of wars are slippery and lie in the power of God.”

Ambiguities of this type led to difficulties of establishing the value of the *Agree Parameter*: Local Agree or Long Distance Agree? Such situations eventually triggered the re-setting of this parameter, in favor of the more constrained grammar, the one in which definiteness is valued by means of LA, a system which generates fewer ambiguities. The re-setting of definiteness valuation illustrates an instance where the *Subset Principle* is diachronically relevant. Roberts (2007: 260) shows that „the Subset Principle might [...] lie behind the phenomenon of ‘restriction of function’, whereby in one system a given operation applies more freely than in another”.

8. Conclusions

1. In Old Romanian, the definite article suffixed to the noun / adjective may occupy the first position of the DP, but also a lower position. In particular, indefinite constituents such as indefinite quantifiers and adjectives or indefinite Gens may precede the definite noun. Old Romanian thus disposes of *Long Distance Agree* in the valuation of definiteness. Distributionally, the lower article is conditioned mostly by a post-nominal Gen or modifier.

2. The lower article is evidence that the Romanian enclitic definite article originates in a post-posed demonstrative, following the same steps as suggested for Scandinavian by Roehrs (2006). It also confirms that the article should be viewed as a *suffix* combining with the N in the lexicon.

3. The presence of suffixed definite article leads to a different system of valuing the [*idef*] feature in D by the [*u+def*] feature carried by the definite noun.

4. At some point in the evolution of Romanian, definiteness became a concord feature for adjectives; the latter optionally entered the derivation with uninterpretable unvalued definite feature, valued by Agree with the noun. It is reasonable to assume that it was precisely *the possibility of valuing definiteness on pre-nominal adjectives that ultimately led to the Modern Romanian requirement that the constituent that values the [*idef*] feature of D should be the first AP/NP below D.*

5. In Old Romanian, *Long Distance Agree* apparently co-exists with *Local Agree*, a factor that may cause ambiguity. Consequently, Romanian settles for Local Agree, selecting the more restrictive grammar.

6. While in Old Romanian there is *Long Distance Agree* and *Long Distance Move*, Modern Romanian loses both options. Changes in these parameters lead to the disappearance of a number of DP structures involving Long Distance Move/Agree. Thus, all patterns involving movement of an XP across the demonstrative or checking of the definiteness feature across a demonstrative are lost.

References

- Akiyama, Masahiro. 2004. "Multiple Nominative Constructions in Japanese and Economy". *Linguistic Inquiry* 34.4., 671-683.
- Barbu, Ana Maria. 2004. *Sintaxa determinantilor. Analiză lingvistică și computațională*. București: All.
- Bernstein, Judy. 1991. "DPs in French and Walloon: Evidence for Parametric Variation in Nominal Head Movement". *Probus* 3.2, 101-126.
- Bernstein, Judy. 1993. "The Syntactic Role of Word Markers in Null Nominal Constructions". *Probus* 5, 5-38.
- Bernstein, Judy. 2001. "Focusing the "Right" Way in Romance Determiner Phrases". *Probus* 13, 1-29.
- Borer, Hagit. 2005. *In Name Only. Structuring Sense*. Oxford: Oxford University Press.
- Brâncuș, Gr. 2004. *Introducere în istoria limbii române*. București: Editura Fundației Româna de Măine.
- Brugé, Laura. 2000. *Categorie funzionali del nome nelle lingue romanze*. Milan: Cisalpino.
- Chomsky, Noam. 1995. *The Minimalist Program*, Cambridge, Mass : MIT Press.
- Cinque, Guglielmo. 1993. "A Null Theory of Phrase and Compound Stress". *Linguistic Inquiry* 24, 3.
- Cinque, Guglielmo. 2004. "A Phrasal Movement Analysis of the Romanian DP". *Studia Linguistica et Philologica in honorem D.Irimia* ed. by A.Minut & E.Munteanu, Iași: Ed. Editura Universității "A. I. Cuza". 129-142.
- Cornilescu, Alexandra. 1992. "Remarks on the Determiner System of Rumanian: the Demonstratives *AL* and *CEL*". *Probus* 4, 189-260.
- Cornilescu, Alexandra. 1995. "Romanian Genitive Constructions", *Advances in Romanian Linguistics* ed. by Guglielmo Cinque & Giuliana Giusti, Oxford: Oxford University Press, 1-52.
- Cornilescu, Alexandra. 2004. "Romanian Genitives Revisited". *Bucharest Working Papers in Linguistics*.
- Coteanu, Ion. 1956. "Despre poziția articolului în limba română". *Studii și cercetări lingvistice* VII, 1-2.
- Croitor, Blanca. 2008. "Aspecte privind acordul în determinare în limba română veche". *Limba română – Dinamica limbii, dinamica interpretării* ed. by G. Pană Dindelegan, București: EUB, 213-218.
- Densusianu, Ovid. 1961. *Istoria limbii române*. București: Editura Științifică.
- Dimitrescu, F. (ed.). 1978. *Istoria limbii române*. București: Editura Didactică și Pedagogică.
- Dimitrova-Vulchanova, M. & G. Giusti, 1998. "Fragments of Balkan Nominal Structure". *University of Venice Working Papers in Linguistics* 8, 1, 141-172.
- Dobrovie-Sorin, Carmen. 1987. "A propos de la structure du groupe nominale en roumain". *Rivista di gramatica generativa* 12, 123-152.
- Dobrovie-Sorin, Carmen & Ion Giurgea. 2006. "The Suffixation of Definite Articles in Balkan Languages". *Revue roumaine de linguistique* LI, 1, 73-104.
- Farkas, D. H. de Swart. 2007. "Article Choice in Plural Generics". *Lingua* 117, 1657-1676.
- Farkas, D., K. von Heusinger. 2003. "Stability of Reference and Object Marking in Romanian". Presentation at *Workshop on Direct Reference and Specificity*, Vienna, August 2003.
- Gheție, Ion. 1975. *Baza dialectală a românei literare*. București: Editura Academiei.
- Giusti, Giuliana. 1993. *La sintassi dei determinanti*. Padua: Unipress.
- Giusti, Giuliana. 1996. "Is There a Focus and a Topic Phrase in the Noun Phrase?". mss., University of Venice.
- Giusti, Giuliana. 1998. "The Rise of a Functional Category. From Latin ILLE to the Romance Article and Personal Pronoun". *University of Venice Working Papers in Linguistics* 8, 2, 53-71.
- Giusti, Giuliana. 2005. "At the Left Periphery of the Romanian Noun Phrase". *On Space and Time in Language* ed. by M. Coene & L. Tasmowski, Cluj Napoca: Clusium. 23-49.
- GALR 2005 – *Gramatica limbii române*. 2005. București: Editura Academiei Române.
- Graur, Al. 1967. "De nouveau sur l'article postposé en Roumain". *Revue roumaine de linguistique* 1, 3-18.
- Giurgea, Ion Tudor. 2008. *Recherches sur la Structure Interne des Pronoms et des Expressions Nominales sans Nom Exprimé*. PhD dissertation, Université Paris 7 "Denis Diderot".
- Grosu, Al. 1988. "On the Distribution of Genitive Phrases in Romanian". *Linguistics* 26, 931-949.
- Huddleston, R & G. Pullum. 2002. *The Cambridge Grammar of the English Language*. Cambridge: Cambridge University Press.
- Jordan, I. & M. Manoliu. 1965. *Introducere în lingvistica romanică*. București: Editura Didactică și Pedagogică (Spanish edition – 1972, *Manual de lingvistica romanică*, Rev., reelaboración parcial y notas pro Manuel Alvar, Madrid, Editorial Gredos).
- Isac, Daniela. 2006. "In Defense of a Quantificational Account of Definite DPs". *Linguistic Inquiry* 37, 2, 275-288.
- Julien, Marit. 2005. *Nominal Phrases from a Scandinavian Perspective*. Amsterdam: John Benjamins.
- Kamp, H. & U. Reyle. 1993. *From Discourse to Logic*. Dordrecht: Kluwer.

- Koptjevskaya-Tamm, Maria. 2005. "Maria's ring of gold: Adnominal Possession and Non-anchoring Relations in European Languages". *Possessives and Beyond: Semantics and Syntax*. ed. by K. Ji-Young *et al.*, Amherst.
- Laenzlinger, Christopher. 2005. "Some Notes on DP-Internal Movement". *GG@G* 4:227-260.
- Longobardi, Giuseppe. 1994. "Reference and Proper Names: a Theory of N-movement in Syntax and Logical Form". *Linguistic Inquiry* 25, 4, 609-665.
- Longobardi, Giuseppe. 2001. "The Structure of DPs: Some Principles, Parameters and Problems". *The Handbook of Contemporary Syntactic Theory* ed. by M. Baltin & C. Collins. Blackwell, 562-603.
- Lyons, Christopher. 1999. *Definiteness*, Cambridge: Cambridge University Press.
- Manoliu-Manea, Maria. 1993. *Gramatică, pragmasemantică și discurs*. București: Litera.
- Niculescu, Alexandru, 1990. *Outline history of the Romanian Language*. Padua: Unipress.
- Ortmann, A & A. Popescu. 2000. "Romanian definite articles are not clitics". *Clitics in Phonology, Morphology and Syntax* ed. by B. Gerlach & J. Grijzenhout. Amsterdam: John Benjamins.
- Pană Dindelegan, Gabriela. 2008. "Tipuri de gramaticalizare. Pe marginea utilizărilor gramaticalizate ale prepozițiilor *de* și *la*". *Limba română. Dinamica limbii, dinamica interpretării* ed. by Gabriela Pană Dindelegan, 227-239. Bucharest, EUB.
- Pesetsky, D. & E. Torrego. 2007. "The Syntax of Valuation and the Interpretability of Features". *Phrasal and Clausal Architecture: Syntactic derivation and interpretation* ed. by S. Karimi, V. Samiian & W. K. Wilkins. Amsterdam: John Benjamins. 262-294.
- Renzi, Lorenzo. 1993. "L'articolo posposto rumeno in diacronia e in sincronia". *Revue Roumaine de Linguistique* XXXVIII, 4, 307-323.
- Renzi, Lorenzo. 1997. "Fissione di lat. ILLE nelle lingue romanze". *Italica et Romanica. Festschrift für Max Pfister zum 75.*, ed. by G. Holtus, J. Kramer & W. Siewckhard. Tübingen: Niemeyer.
- Roberts, Ian. 2007. *Diachronic Syntax*, Cambridge: Cambridge University Press.
- Roehrs, Dorian. 2006. *The Morpho-Syntax Of The Germanic Noun Phrase: Determiners Move Into The Determiner Phrase*. PhD dissertation, Indiana University.
- Rosetti, Al. 1968. *Istoria limbii române de la origini până în secolul al XVII-lea*. București: Editura pentru Literatură și Artă.
- Stateva, Penka. 2002. "Possessive clitics and the structure of nominal expressions". *Lingua* 112, 647-690.
- Stowell, T., 1989. "Subjects, Specifiers, and X-Bar Theory". *Alternative Conceptions of Phrase Structure* ed. by M. Baltin & A. Kroch, The University of Chicago Press.
- Tasmowsky, Liliane. 2009. "Le roumain, entre langues romanes et langues balkaniques". Conference at the University of Bucharest, may 2009.
- Zwicky, A & G. Pullum. 1983. "Cliticization vs. Inflection: English *n't*". *Language* 59, 3, 502-513.

Corpus

- DÎR – *Documente și însemnări românești din secolul al XVI-lea*, text stabilit și indice de Gheorghe Chivu, Magdalena Georgescu, Magdalena Ioniță, Alexandru Mareș și Alexandra Roman-Moraru, Introducere de Alexandru Mareș. București: Editura Academiei, 1979.
- Costin – Miron Costin, *Opere alese*, edited by P.P. Panaitescu, București: Editura Tineretului, 1966
- Cronicarii Munteni*, edited by Al. Piru, București, Editura Tineretului, 1964.
- „Letopisețul Cantacuzinesc”, in *Cronicarii Munteni*.
- R. Popescu, „Letopisețul Bălenilor”, in *Cronicarii Munteni*.
- R. Greceanu, „Cronica”, in *Cronicarii Munteni*.
- Constantin Cantacuzino, „Istoria Țării Rumânești”, in *Cronicarii Munteni*.
- Cantemir – Dimitrie Cantemir, *Istoria ieroglifică*, Colecția „Biblioteca pentru toți”. 1983. Editura Minerva, București.
- Ureche– Grigore Ureche, *Letopisețul Țării Moldovei*, ed. by P. P. Panaitescu. 1955. București: ESPLA.
- Biblia – Biblia sau dumnezeiasca scriptură*, București, 1688.