

## **BIVALENT VERBS<sup>1</sup>**

**Abstract:** *This paper is a short presentation of the bivalent verbs by considering the internal argument from semantic and syntactic reasons and by introducing a special relationship between the DO nouns and the unstressed accusative forms of the personal pronouns, named Object Agreement.*

**Keywords:** *bivalent verbs, direct object, Object Agreement.*

Syntactic rules in a grammar account for the grammaticality of sentences, and the ordering of words and morphemes. The sentences are structured into successive components, consisting of single words or groups of words. These groups and single words are called constituents (i.e. structural units), and when they are considered as part of the successive unraveling of a sentence, they are known as its immediate constituents. Sentences in any language are constructed from a rather small set of basic structural patterns and through certain processes involving the expansion or transformation of these basic patterns. When we consider sentence types from another perspective, it can be shown that each of the longer sentences of a language (and these are in the majority usually) is structured in the same way as one of a relatively small number of short sentences which are impossible to reduce to a short form.

The first step of my research is to identify the verb phrase constituents and their relationships, for Romanian and English languages. The translation examples analyzed are representative for literary style that I considered closer to flexibility of natural language. Each example is syntactically represented with a tool for drawing linguistic syntax trees, named Linguistic Tree Constructor. Also, each example has its verb pattern which can be used in a different level to create rules and to evaluate them.

The second step of the research is to implement the verb patterns in order to identify the verb constituents and their order for any kind of predication.

In this paper I introduce the bivalent verbs, the organization of their constituents and I analyze the syntactic properties.

There are some verbs about which we can say they are bivalent interpersonal verbs, when we refer to the number of persons who take part to the event. Generally speaking, we can talk about any verb's valence, which designates the number of actors who take part to the event. A verb that designates an action referring to persons, a feeling or a human state, is characterized, along with usual

---

<sup>1</sup> **Nadia Luiza DINCĂ**, Research Institute for Artificial Intelligence, Bucharest, Romania  
hnadia\_luiza@hotmail.com

linguistic features, by its valence. The valence represents the number of the persons which the verb refers to. Thus, a bivalent verb would be a verb with valence 2.

The general schema to represent the relation between the verb (predication) and the internal argument returns to clitics and their relationships to the direct objects:

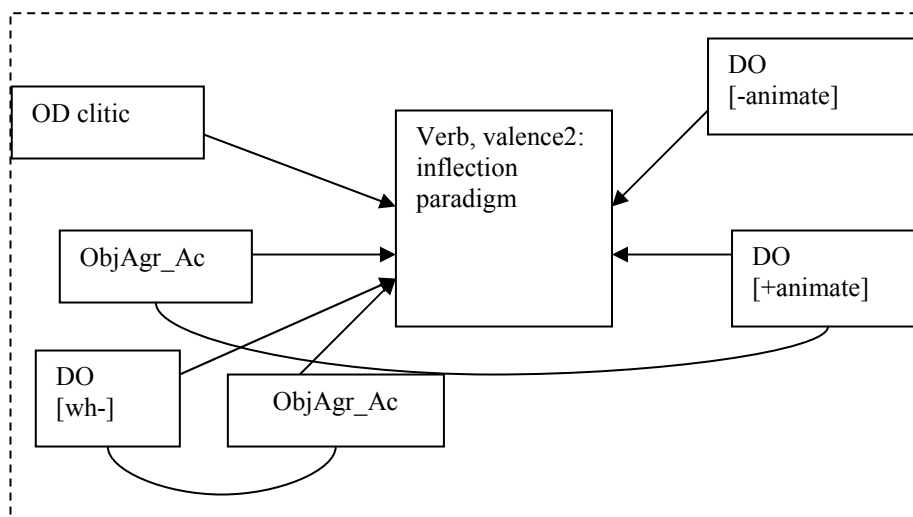

Fig. 1: General schema to represent the verb phrase with bivalent head

A possible verb pattern conceives the direct object without a prepositional construction. For the next two haiku examples<sup>1</sup> (Ex. 1), the analysis shows the verb pattern with bivalent head and a nominal DO, and the syntactic trees created starting from this pattern (Fig. 2.a, Fig. 2.b):

Ex. 1:

*Privighetoarea*  
*a urmat conservatorul,*  
*în cuibul matern.*

*The nightingale*  
*attended the Music Academy,*  
*within the maternal nest.*

Verb pattern:

$[V+ NP_{AC}^2[OD]]ro \Leftrightarrow [V+ NP_{AC}[OD]]en$

<sup>1</sup> Florin Vasiliu, 1993, "Tolba cu licurici", Ed. Haiku, București, p. 20

<sup>2</sup> NP<sub>AC</sub> = noun phrase with a nominal head which is in the accusative case

Syntactic Trees:

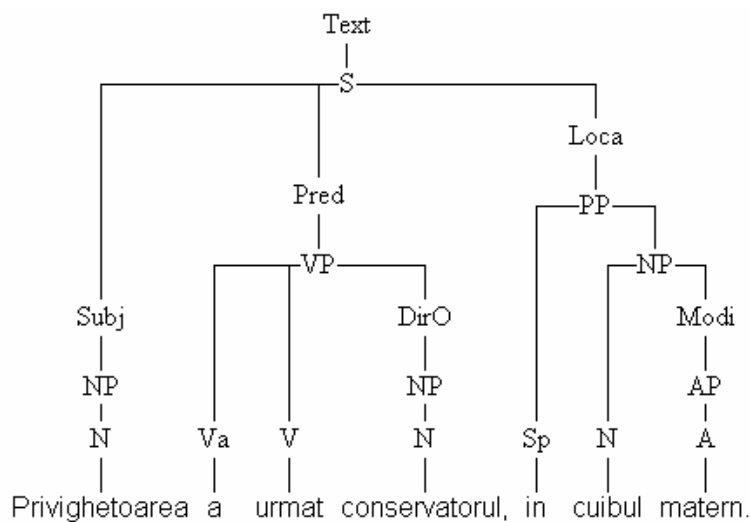

Fig. 2.a

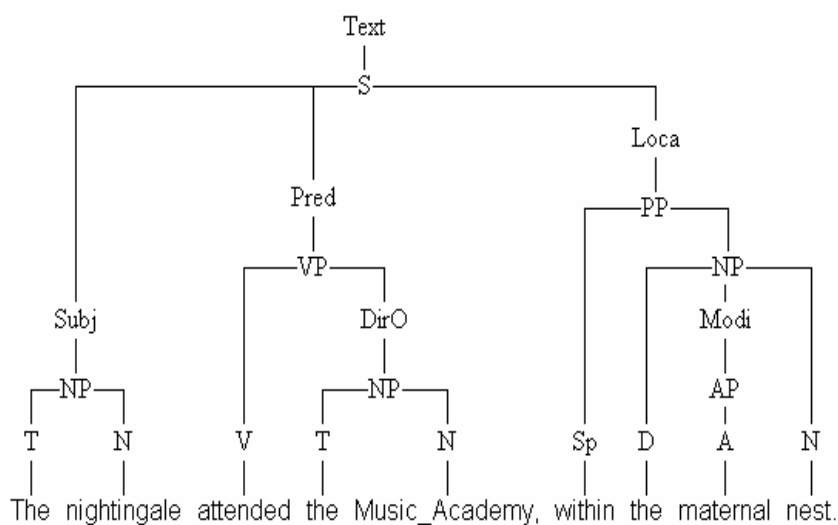

Fig. 2.b

The direct object is marked in certain situations by the preposition “pe”, which in such constructions loses its original meaning (“on”, “above”). The usage rules for this marker are complex and insufficiently codified; both semantics and

morphology comes into play. The unstressed accusative forms are used in the same sentence with another accusative pronoun or noun as a double accusative. The special case of the double accusative is considered in this paper by the means of a special grammatical label, *ObjAgr* (*Object Agreement*) and by modifying the noun phrase expansion [1].

An example where we have to create the direct object by using the unstressed form of the accusative pronoun is showed in the next haiku<sup>1</sup> (Ex. 2) and it is illustrated by two syntactic trees, available for Romanian and English versions (Fig. 3.a, Fig. 3.b):

Ex. 2:

|  |   |
|--|---|
| <p><i>Cartea Genezei</i><br/><i>o citesti in brazdele</i><br/><i>negre de april.</i></p> | <p><i>The Genesis Book:</i><br/><i>you can read it in the</i><br/><i>black</i><br/><i>furrows of April.</i></p> |
|--|---|

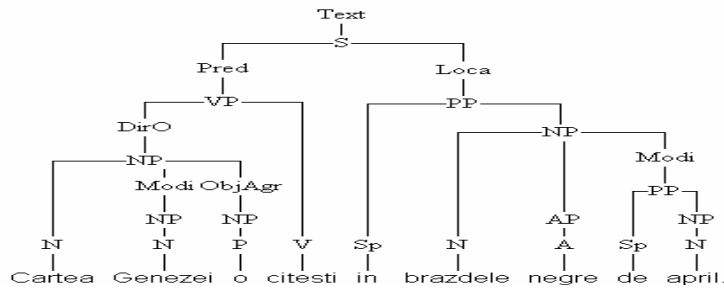

Fig. 3.a

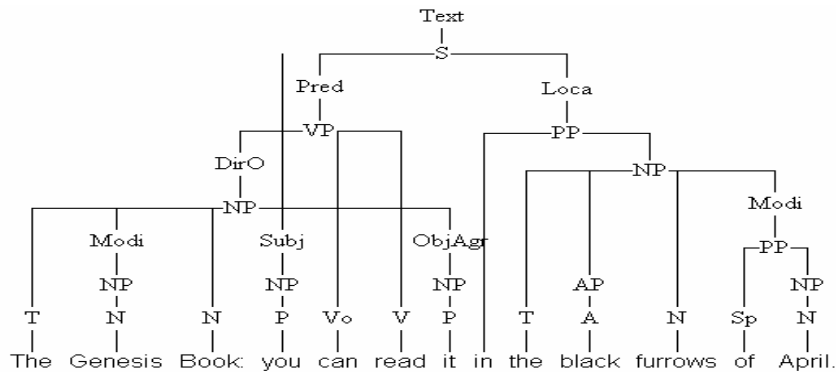

Fig. 3.b

<sup>1</sup> Șerban Codrin, 1994, "Dincolo de tăcere", Ed. Haiku, București, p. 14

The verb patterns which result from these two sentences prove the fact that a bivalent verb requires one core argument accomplished by the direct object. The grammatical feature ObjAgr joints the noun head and the unstressed pronoun by creating an agreement of person, number, gender and case between the DO noun and the pronominal clitic:<sup>1</sup>

Verb Pattern:

$$[\text{NP}_{\text{AC}}[\text{N} + \text{NP}_{\text{ObjAgr}}] + \text{V}]_{\text{ro}} \Leftrightarrow [\text{V} + \text{NP}]_{\text{en}}$$

The prepositional phrase having DO as syntactic label, doubled inside the verb phrase by the unstressed accusative form of personal pronoun, proves the grammatical feature ObjAgr and establish a semantic and syntactic relationship between the noun head and the nominal substitute (Ex. 3, Fig. 4.a, Fig. 4.b):

Ex. 3:

*pe un nebun nu-l va crede.*

*he will not believe a fool.<sup>2</sup>*

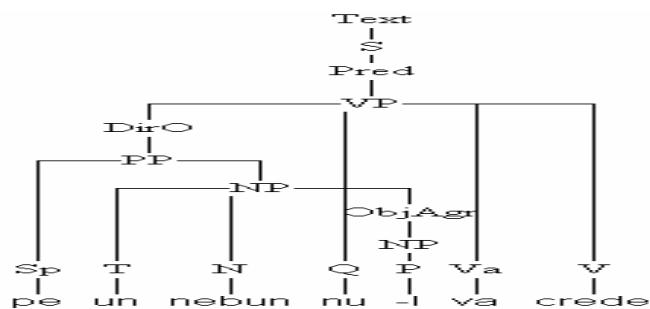

Fig. 4.a

<sup>1</sup> The whole construct N+NP<sub>ObjAgr</sub> is involved semantically and syntactically in building the direct object.

<sup>2</sup> W. Shakespeare, 2000, "Regele Lear", Ediție bilingvă, pp. 86-87

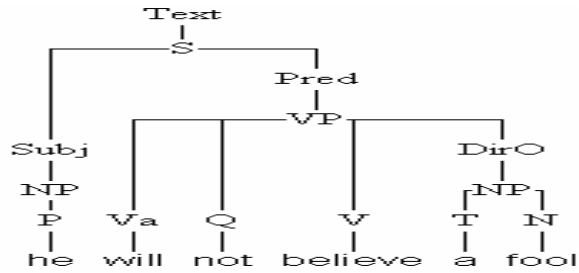

Fig. 4.b

Verb pattern:

$[PP[pe [NP_{AC} [N + NP_{ObjAgr}]]] + V]_{ro} \Leftrightarrow [V + NP_{AC}]$

From the point of view of syntactic dependency, the verb phrase from the next example is based on the syntactically obligatory dependencies, where the determiner cannot be canceled. It is about the relationship between the verb and the direct object: *văd* ← *zeii*, *îi* → *iau*, *îi* → *înșurubez*; *see* ← *the gods*, *take* ← *them*, *thrust* ← *them*:

Exemplul 4:

aieva văd zeii de fildeș,  
 îi iau în mână și  
 îi înșurubez râzând, în lună,<sup>1</sup>

I clearly see the ivory gods,  
 I take them in my hands and  
 thrust them, laughing, in the moon<sup>2</sup>

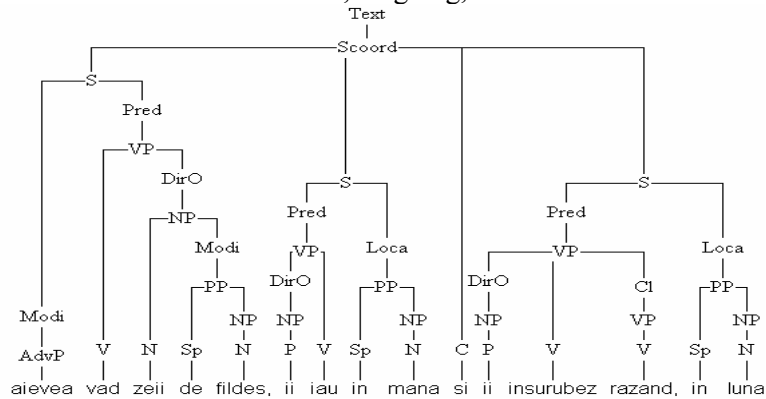

Fig.5.a

<sup>1</sup>[http://www.imaginelife.ro/poezii/poezii-de-dragoste/nichita\\_stanescu\\_-\\_varsta\\_de\\_aur\\_a\\_dragostei/](http://www.imaginelife.ro/poezii/poezii-de-dragoste/nichita_stanescu_-_varsta_de_aur_a_dragostei/)

<sup>2</sup>[http://www.romanianvoice.com/poezii/poezii\\_tr/goldenage.php](http://www.romanianvoice.com/poezii/poezii_tr/goldenage.php)

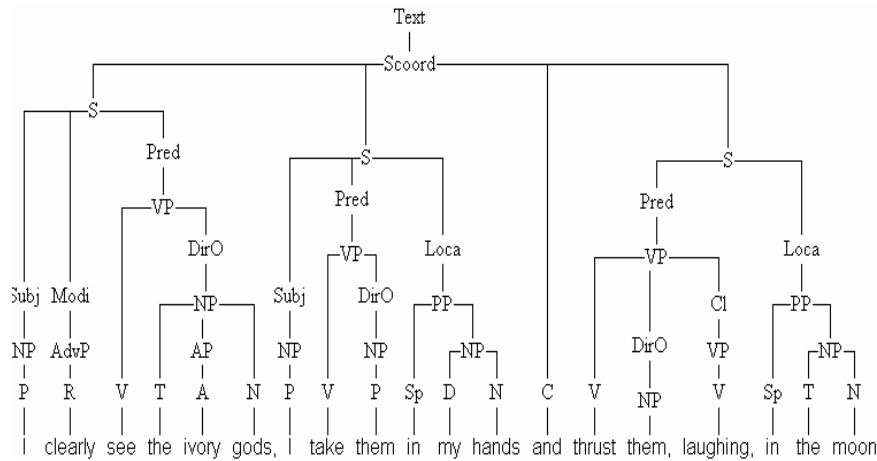

Fig. 5.b

Verb pattern:

$$[V + NP_{AC}] [NP_{AC} [N^{*1}] + V] [NP_{AC} [N^{*}] + V]_{ro} \Leftrightarrow [V + NP_{AC}] [V + NP_{AC} [N^{*}]] [V + NP_{AC} [N^{*}]]_{en}$$

The obligatory determiner rule is interesting for the semantic reason, too, when the determiner is a polysemantic word. In the next example, the first meaning of the verb “to cut” is “to separate into parts with or as if with a sharp-edged instrument; to separate from a main body; detach”. The meaning of this verb used in Nichita Stănescu’s lyrics is “to pass through or across; cross”. If we consider the verb without the context, then the word is ambiguous and the context has to disambiguate it. In conclusion, the argument “the field” is an obligatory determiner.

Ex. 5:

Câmpul tăindu -l, pe două potcoave  
calul meu saltă din lut, fumegând<sup>2</sup>

Cutting through the field -up on two shoes  
my horse leaps, steaming, from the clay.<sup>3</sup>

<sup>1</sup> N\* is the specification used for the pronoun category.

<sup>2</sup> [http://art-zone.ro/poezii/nichita\\_stanescu/O\\_calarire\\_in\\_zori.html](http://art-zone.ro/poezii/nichita_stanescu/O_calarire_in_zori.html)

<sup>3</sup> [http://www.romanianvoice.com/poezii/poezii\\_tr/horseback.php](http://www.romanianvoice.com/poezii/poezii_tr/horseback.php)

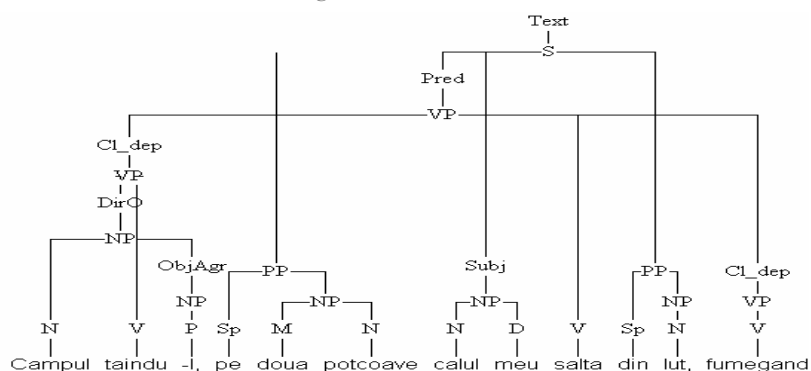

Fig. 5.a

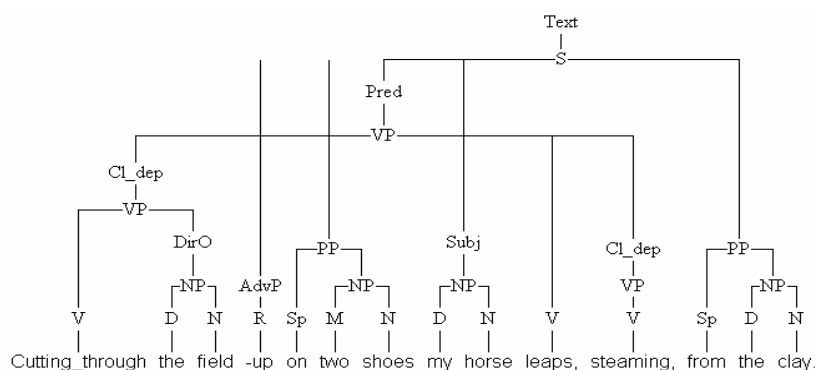

Fig. 5.b

The verb pattern:

$$[NP_{AC} + V + NP_{ObjAgr}]_{ro} \Leftrightarrow [V + NP_{AC}]_{en} = [NP_{AC}[N + NP_{ObjAgr}] + V]_{ro} \Leftrightarrow [V + NP_{AC}]_{en}$$

In conclusion, the bivalent verb (predication) takes an internal argument inside the maximal projection of that verb by considering both the syntactic and semantic reasons. The Object Agreement relationship between the DO nouns and the unstressed accusative forms of the personal pronoun is justified by the agreement of number, case, person and gender.

The next direction of this research aims to implement the syntactic information created by the small set of basic structural patterns in order to develop a syntactic analyzer, which identifies constituents of the sentence, states the part of speech each word belongs to, describes the inflexion involved, and explains the relationship each word related to the others.

***Bibliography***<sup>1</sup>

- Dincă (Huțuliac), N.L., 2006, “Frames for a PC-PATR implementation of the Romanian transitive verbs”, in C. Forăscu, D. Tufis, D. Cristea (eds.) Proceedings of the Workshop *Linguistic Resources and Tools for Processing Romanian Language*, Iași, University “Al.I. Cuza” Publishing House.
- Shakespeare, W., 2000, “Regele Lear”, Ediție bilingvă, Iași, Institutul European.
- Vasiliu, F., 1993, “Tolba cu licurici”, București, Editura Haiku.
- Șerban Codrin, 1994, “Dincolo de tăcere”, București, Ed. Haiku, p. 14.
- [http://www.imaginelife.ro/poezii/poezii-de-dragoste/nichita\\_stanescu\\_-\\_varsta\\_de\\_aur\\_a\\_dragostei/](http://www.imaginelife.ro/poezii/poezii-de-dragoste/nichita_stanescu_-_varsta_de_aur_a_dragostei/)
- [http://art-zone.ro/poezii/nichita\\_stanescu/O\\_calarire\\_in\\_zori.html](http://art-zone.ro/poezii/nichita_stanescu/O_calarire_in_zori.html)
- [http://www.romanianvoice.com/poezii/poezii\\_tr/horseback.php](http://www.romanianvoice.com/poezii/poezii_tr/horseback.php)
- [http://www.romanianvoice.com/poezii/poezii\\_tr/goldenage.php](http://www.romanianvoice.com/poezii/poezii_tr/goldenage.php)

---

<sup>1</sup> It is not a large list of scientific or literary titles, because the paper is the individual research on verbal phrase and on its constituents. Its aim was not the state of art of the verbal phrase analysis, but the representation of bivalent verbs and their constituents, for significant translation examples.